

Product datasheet

Dock leveler

ASSA ABLOY DL6120T

ASSA ABLOY
Entrance Systems

Experience a safer
and more open world

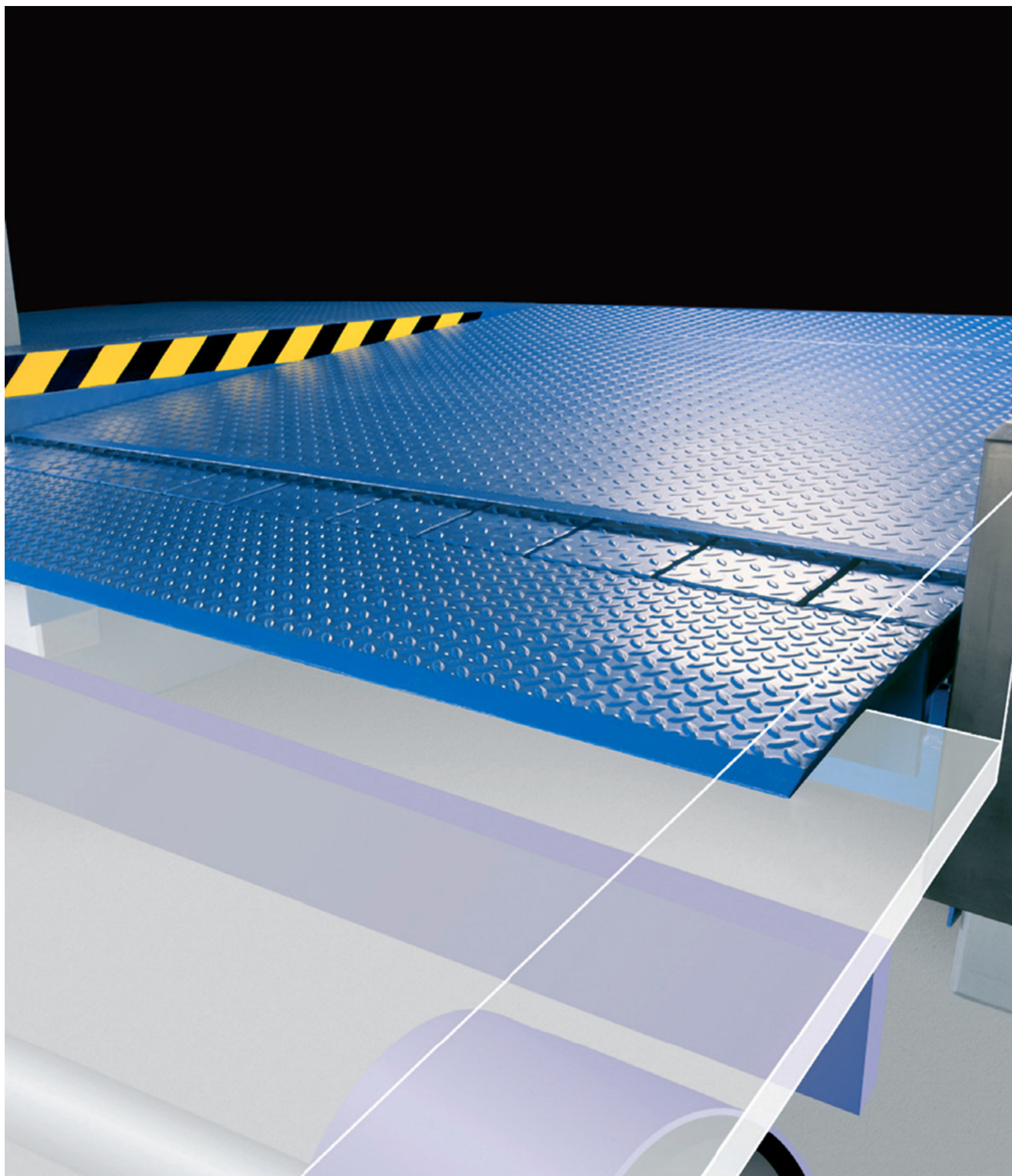

Copyright and Disclaimer Notice

Although the contents of this publication have been compiled with the greatest possible care, ASSA ABLOY cannot accept liability for any damage that might arise from errors or omissions in this publication. We also reserve the right to make appropriate technical modifications/replacements without prior notice.

No rights can be derived from the contents of this document.

Color guides: Color differences may occur due to different printing and publication methods.

ASSA ABLOY as word and logo are trademarks belonging to the ASSA ABLOY Group.

No part of this publication may be copied or published by means of scanning, printing, photocopying, microfilm or any other process whatsoever without prior permission in writing by ASSA ABLOY.

© ASSA ABLOY 2006-2022.

All rights reserved.

Technical facts

Features

Sizes - leveler height	600, 700, 800, 900 mm	
Sizes - nominal length*	2000, 2500, 3000, 3500, 4000, 4500 mm	
Sizes - nominal width	1750, 2000, 2200, 2250 mm	
Vertical working range	Above dock:	0 - 660 mm
	Below dock:	0 - 440 mm
Platform tear plate	8 mm (8/10)	
Surface treatment	Standard:	RAL 5010
	Option:	RAL 9005
		RAL 3002
		RAL 6005
		Hot dip galvanised
Control unit	Leveler control Door control Shelter control Fault & service indicator	

* Other sizes are available on request

Performance

Load capacity	6 tonnes (60kN)
Max. point load	6,5 N / mm ² (8 mm tear plate)
Motor hydraulic unit	1,5kW
Mains supply	400V 3-phase, 230V 3-phase
Control unit protection class	IP54
Allowable oil types	ASSA ABLOY standard hydraulic oil (-20°C - +60°C) ASSA ABLOY low temperature hydraulic oil (-30°C - +60°C) ASSA ABLOY bio hydraulic oil (-20°C - +60°C)
Magnetic valves	24V/DC 18W S1
Surface treatment paint class 1	80 µm Corrosive Category C2 M acc. DIN EN ISO 12944-2
Surface treatment paint class 3	160 µm Corrosive Category C3 M acc. DIN EN ISO 12944-2
Surface treatment galvanised	Hot dip galvanised 80 µm Corrosive category C4 & C5-I M acc. DIN EN ISO 12944-2

Contents

Copyright and Disclaimer Notice.....	2
Technical facts.....	3
Features.....	3
Performance.....	3
1. Description.....	6
1.1. General.....	6
1.1.1. Application.....	6
1.1.2. Mode of operation.....	6
1.1.3. Overview.....	6
1.1.4. Standard.....	6
1.1.5. Options.....	6
1.2. Telescopic Lip.....	7
1.2.1. Lip material.....	7
1.2.2. Lip type.....	7
1.2.3. Lip shapes.....	7
1.2.4. Bevelled lip.....	7
1.3. Platform.....	8
1.3.1. Platform tear-plate thickness.....	8
1.3.2. EPDM seal.....	8
1.3.3. Front cover curtain.....	8
1.3.4. Slip protection / noise reduction.....	8
1.4. Surface.....	9
1.4.1. Painting.....	9
1.4.2. Hot galvanising.....	9
1.5. Frames - connection to building.....	10
1.5.1. T - leveler frame for embedding in concrete.....	10
1.5.2. T - 200 leveler frame for embedding in concrete.....	10
1.5.3. W - leveler frame for welding.....	10
1.5.4. F - flat frame for welding.....	11
1.5.5. P - pit frame for welding.....	11
1.5.6. B - box-frame.....	11
1.6. Docking control systems.....	12
1.6.1. 950 Docking LA TD.....	12
1.6.2. 950 Docking DLA TD.....	12
1.6.3. 950 Docking LSA TD.....	12
1.6.4. 950 Docking DLSA TD.....	12
1.6.5. 950 Docking power cable.....	12
1.7. Equipment.....	13
1.7.1. Buffers.....	13
1.7.2. ASSA ABLOY DE6190WC Wheel chock.....	15
1.7.3. ASSA ABLOY DE6090TLS Traffic light system.....	15
1.7.4. ASSA ABLOY DE6090DL Dock light Heavy Duty LED.....	15
1.7.5. ASSA ABLOY DE6090FL Fan light.....	15
1.7.6. Parking guides.....	15
1.7.7. ASSA ABLOY DE6190DI Dock-IN Autodock.....	16
1.7.8. Panels for ISO loading system.....	18
2. Selection guide.....	19
2.1. Load capacity according to EN 1398.....	19
2.1.1. Rated load.....	19
2.1.2. Axle load.....	19
2.1.3. Dynamic load.....	19
2.2. Select the load capacity.....	19
2.2.1. Example.....	19
2.3. Select the leveler length.....	20
2.3.1. The calculation.....	20
2.3.2. Example.....	20
2.4. Nominal width.....	20
2.5. Free space under lip.....	20
2.5.1. Steel lip.....	20

2.5.2.	Aluminium lip.....	20
3.	Specifications.....	21
3.1.	Dimensions.....	21
3.2.	Platform thickness.....	21
3.3.	Control units.....	22
3.3.1.	Dimensions.....	22
3.3.2.	Functions.....	22
4.	CEN Performance.....	23
4.1.	Safety according to the European Standard EN 1398.....	23
5.	Building and space requirements.....	24
5.1.	Electrical preparations.....	24
5.2.	Pit preparations.....	25
5.2.1.	T - frame + T-frame 200.....	25
5.2.2.	W - frame.....	25
5.2.3.	F - frame.....	26
5.2.4.	P - frame.....	26
5.2.5.	B - frame.....	27
5.2.6.	T - frame ISO loading system.....	27
6.	Service you can rely on.....	28
	Index.....	29

1. Description

1.1 General

1.1.1 Application

The ASSA ABLOY DL6120T teledock is the optimal efficiency solution in general industry and logistics applications. The telescopic lip precisely bridges the gap between the ramp and the lorry bed. The ASSA ABLOY DL6120T teledock system meets the standard demands of most loading operations and fully complies with rules and regulations of the European Standard EN 1398.

1.1.2 Mode of operation

The operation of the ASSA ABLOY DL6120T teledock is based on an electro-hydraulic telescopic lip, controlled by a semi-automatic control unit.

When the dock leveler is raised, the lip extends and the leveler lowers gently onto the lorry bed. After loading or unloading, the leveler is raised again, the lip retracts and the platform returns to its parking position.

1.1.3 Overview

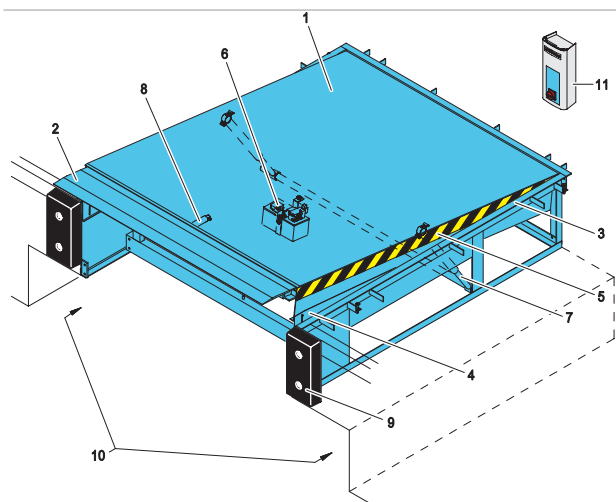

- 1) Leveler platform
- 2) Telescopic lip
- 3) Leveler frame
- 4) Toe guard
- 5) Warning stripes
- 6) Hydraulic Unit
- 7) Lift cylinders
- 8) Telescopic lip cylinder
- 9) Buffers (option)
- 10) Tail lift recess
- 11) Control unit

1.1.4 Standard

Frames - connection to building:	P-frame [pit-frame]
Surface	Painting RAL 5010 or RAL 9005
Hydraulic Equipment	Low noise hydraulic unit Two hydraulic lift cylinders One hydraulic lip cylinder
Lip	Steel lip Bevelled 100 mm Lip length 500 mm

1.1.5 Options

Frames - connection to building	T-200 frame W-frame [frame for welding] F-frame [flat frame for welding] P-frame [pit-frame, max NL=3000] B-frame [box-frame]
Surface	Painting RAL 3002 or RAL 6005 Hot dip galvanised
Hydraulic equipment	Low temperature oil Bio oil
Lip options	Lip length 1000 mm Lip length 345 mm - Ergonomic lip Aluminium lip 2 retracting tongues Tapered lip
Energy & ergonomics	EPDM seal Front cover curtain Slip protection/noise reduction
Equipment	Panels for ISO loading system in thickness 42 mm Panels for ISO loading system in thickness 82 mm Color of panels RAL 9010 outside and RAL 9002 inside

1.2 Telescopic Lip

1.2.1 Lip material

1.2.1.1 Steel telescopic lip

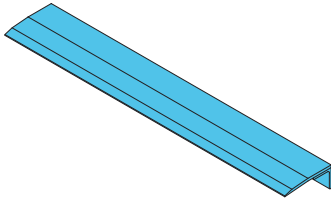

The steel telescopic lip is designed for use by heavy loading equipment. It has a high durability, while it provides medium comfort.

1.2.1.1 Aluminium telescopic lip

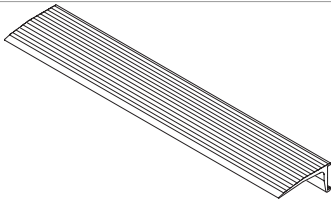

The aluminium telescopic lip is designed to provide maximum comfort to low load-weight loading equipment.

1.2.2 Lip type

1.2.2.1 Standard lip

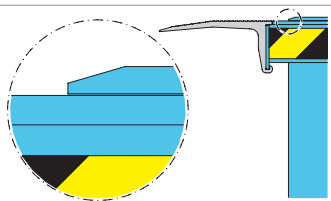

When the standard lip is extended there is always a bump from the lip to the platform of the leveler. The length of the lip is 500 mm or 1000 mm.

1.2.2.1 Ergonomic lip

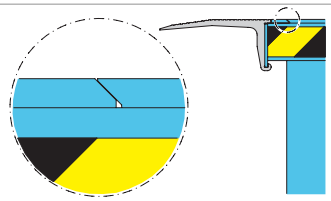

When the ergonomic lip is fully extended it is on the same level line as the leveler platform. Due to the smooth bump free passage shock loads are reduced. Maximal buffer depth is 100 mm. The length of the lip is 345 mm.

1.2.3 Lip shapes

1.2.3.1 Standard telescopic lip

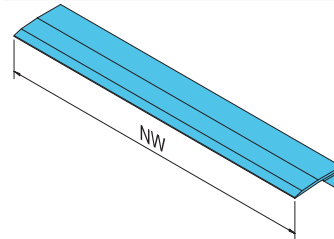

The standard telescopic lip is a single rectangular lip for use with a fleet of vehicles that is a standard size.

1.2.3.1 Tapered telescopic lip

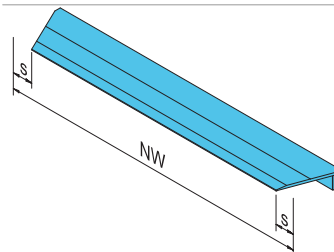

A tapered telescopic lip ensures that the lip reaches the lorry bed, even when the lorry is not parked in the exact centre position. Avoids damage to the truck and interruptions of the dock-in procedure. $s = 100 \text{ mm}$

1.2.3.1 2 retracting tongues

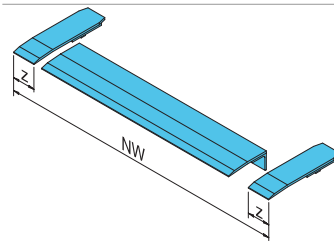

For applications with vehicles of different widths, the telescopic lip can be provided with 2 retracting tongues. On each side a 140 mm wide segment is pushed inside when a smaller vehicle docks.

1.2.4 Bevelled lip

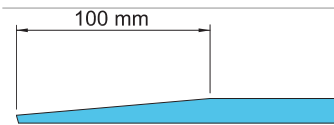

The standard steel lip is 100 mm bevelled, designed to provide maximum comfort and smooth transition from the lip.

1.3 Platform

1.3.1 Platform tear-plate thickness

The 8 mm (8/10) tear-plate is designed for loading and unloading with typical 4 wheel pneumatic-tired fork-lift trucks, and is also suitable for handling equipment with high point loads, such as electric pallet trucks.

1.3.2 EPDM seal

To seal the gap between leveler and pit, an EPDM seal can be factory-installed between the flexible platform and frame. By reducing draughts into the building, working conditions improve and energy savings increase.

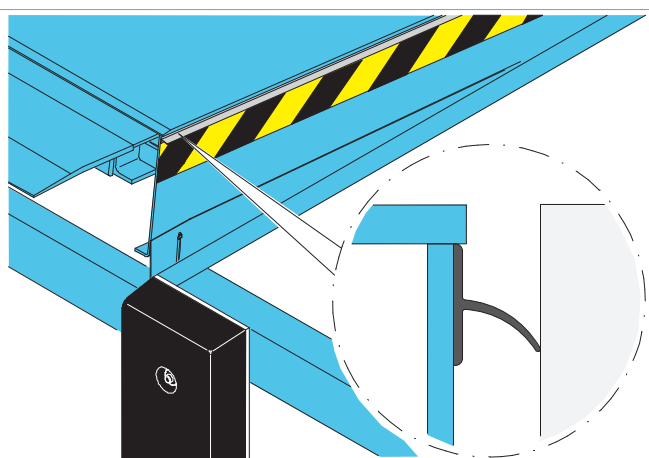

1.3.3 Front cover curtain

A PVC front cover curtain on the platform prevents draught and dirt under the leveler.



1.3.4 Slip protection / noise reduction

Applying a polyurethane slip protection coating on the lip and platform ensures a durable non-slip and noise reduction surface. The effect is a smooth and comfortable surface for handling equipment that is less receptive to wear and tear.

The PU coating material is resistant to impact, to thermal impact and most types of chemicals and it has a high loading capacity.

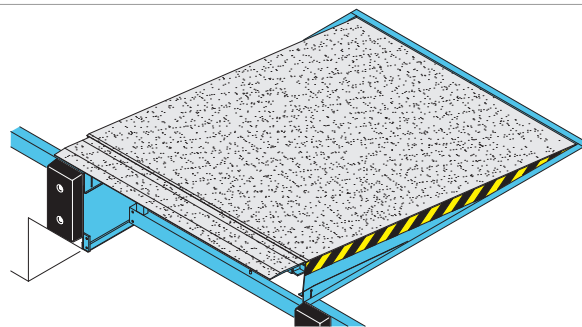

1.4 Surface

1.4.1 Painting

1.4.1.1 Colors

The dock leveler standard finish is painted. The standard colors are:



Colors available as option are:



1.4.1.1 Standard paint class

If the dock leveler is to be used in a rural area, the standard finish is:

- Paint class 1; 80 µm factory painted for corrosive category C2 M

1.4.1.1 Paint classes

If the dock leveler is to be used in an urban or industrial atmosphere, or in a coastal area, it may be appropriate to select an alternative paint class with increased resistance to corrosion C3 M.

- Paint class 3; 160 µm factory painted for corrosive category C3 M

1.4.2 Hot galvanising

To increase corrosion protection to C4 for saline coastal areas or C5-I for aggressive or humid atmospheres, the dock leveler can be delivered with hot dip galvanised (80 µm) steel parts.

1.5 Frames - connection to building

The frame is the leveler's connection point to the building and a rigid support for the leveler.

The ASSA ABLOY DL6120T teledock is available with different frame types. The frame can be embedded in concrete or installed via screws or welding. All frames are illustrated with the tail lift recess. The levelers are also available without tail lift recess.

1.5.1 T - leveler frame for embedding in concrete

The T-frame is installed in one step. The leveler is directly embedded in concrete.

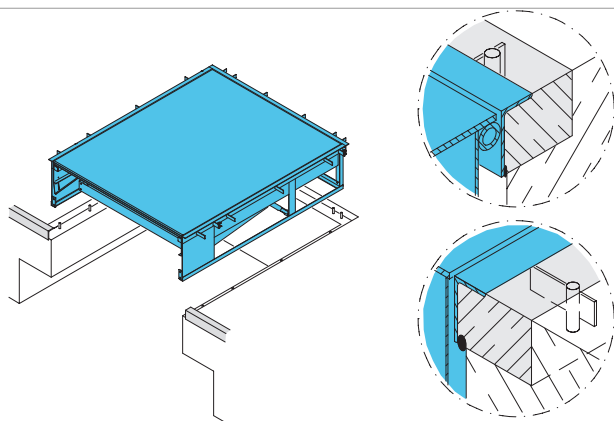

1.5.2 T - 200 leveler frame for embedding in concrete

The rear vertical part of the T-200 frame is prolonged from 100 mm to 200 mm to improve the situation during the process of pouring the concrete to finish floor level in the building, when the dock edge gap of the concrete pit is not fully in line with out pit drawing.

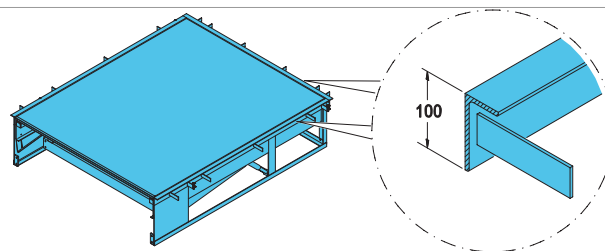

T-frame (standard) 100 mm

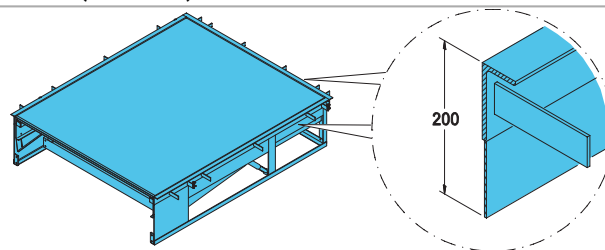

T-frame (standard) 200 mm

1.5.3 W - leveler frame for welding

The W-frame is designed to weld the leveler directly to the floor slab. In case of future replacement, the welding points can be ground away.

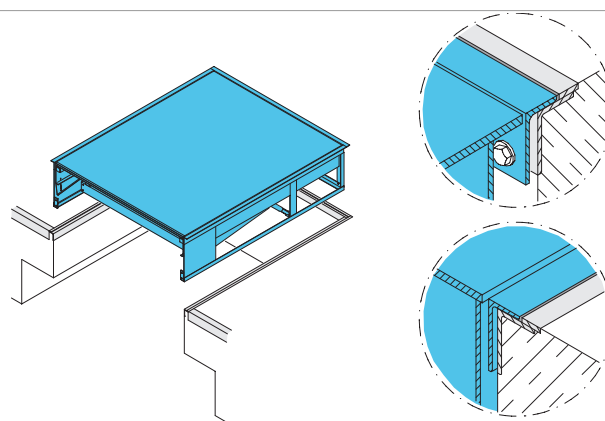

1.5.4 F - flat frame for welding

The F-frame is designed to weld the leveler directly to the floor slab. In case of future replacement, the welding points can be ground away.

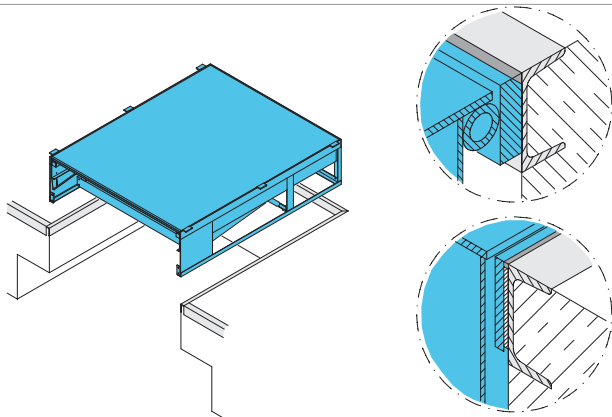

1.5.6 B - box-frame

The B-frame is designed to function as the concrete shutter. Therefore complicated and expensive shutter work is not required.

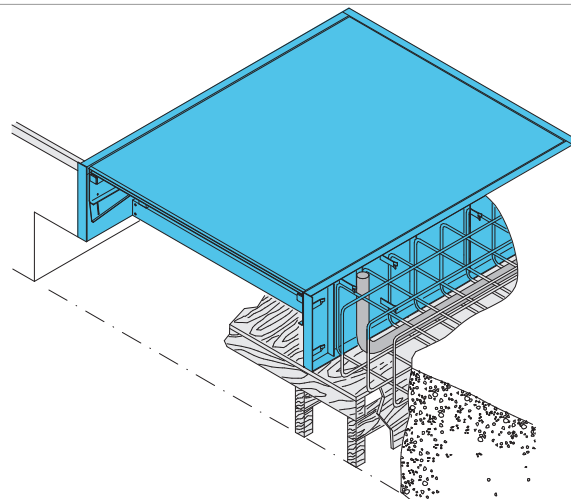

1.5.5 P - pit frame for welding

The P-frame leveler is designed to rest on a sturdy concrete slab at the rear of the pit. The rest of the leveler is welded to the pit edges. This leads to fast installation and replacement.

NL 2000-3000

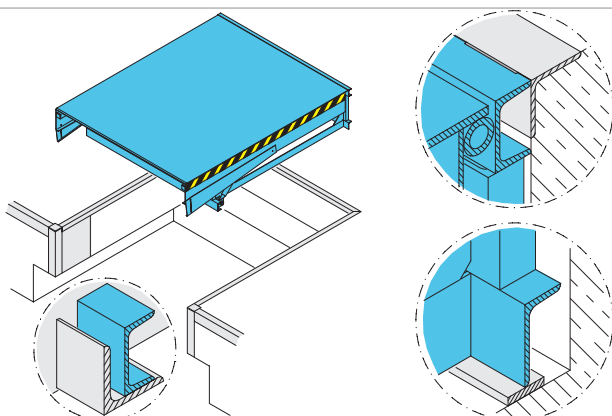

1.6 Docking control systems

1.6.1 950 Docking LA TD

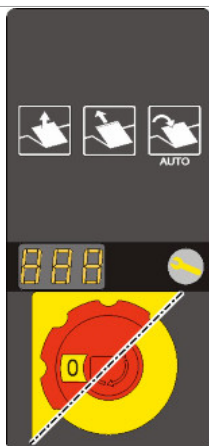

- Hold-to-run button to lift platform.
- Hold-to-run button to position the lip on the truck bed.
- Impulse auto button to put the leveler back in parking position.
- Mains isolator or emergency stop button.
- Interface to incorporate ASSA ABLOY wheel chock.

1.6.2 950 Docking DLA TD

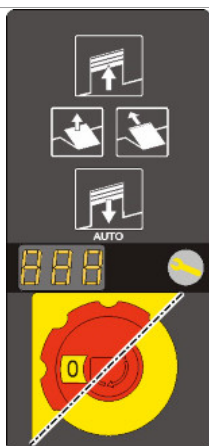

- Hold-to-run button to lift platform.
- Hold-to-run button to position the lip on the truck bed.
- Impulse auto button to put the leveler back in parking position.
- Mains isolator or emergency stop button.
- Interface to incorporate ASSA ABLOY wheel chock.
- Designed to operate an overhead sectional door in the docking station.

1.6.3 950 Docking LSA TD

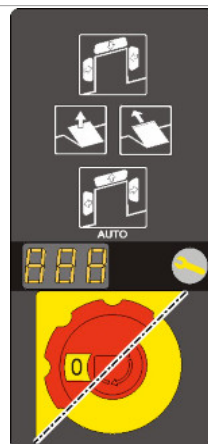

- Hold-to-run button to lift platform.
- Hold-to-run button to position the lip on the truck bed.
- Impulse auto button to put the leveler back in parking position.
- Mains isolator or emergency stop button.
- Interface to incorporate ASSA ABLOY wheel chock.
- Designed to operate an inflatable shelter in the docking station.

1.6.4 950 Docking DLSA TD

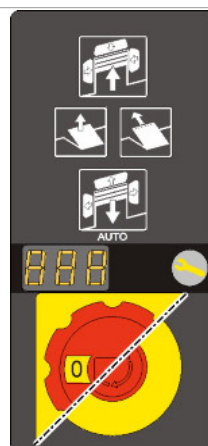

- Hold-to-run button to lift platform.
- Hold-to-run button to position the lip on the truck bed.
- Impulse auto button to put the leveler back in parking position.
- Mains isolator or emergency stop button.
- Interface to incorporate ASSA ABLOY wheel chock.
- Designed to operate an overhead sectional door and an inflatable shelter in the docking station.

1.6.5 950 Docking power cable



- Standard: 1,1 m power cable to connect to mains switch on the wall.
- Option: 1,5 m power cable with CEE-plug, pre-mounted.

1.7 Equipment

1.7.1 Buffers

Buffers placed in front of the dock leveler absorb the energy of a vehicle that accidentally or intentionally hits the building. Buffers are available in various sizes, in fixed or moving models, and with rubber finishing or steel plate and spring function.

1.7.1.1 RS

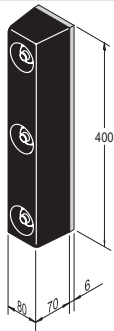

Application

The RS buffer is the economical solution for docking stations where vehicles of equal sizes load and unload.

1.7.1.1 RB

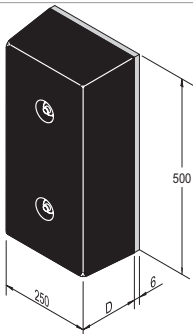

Application

The RB buffer is a large fixed rubber. It is the universal building and vehicle protection solution. Available depths:

- 90 mm
- 140 mm

1.7.1.1 RB with steel front plate

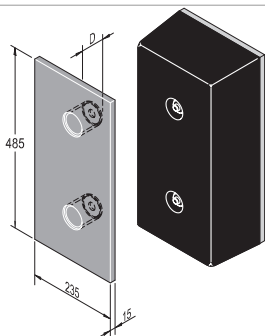

Application

The RB buffer with steel protection front plate increases the building protection and the buffer service life. Available depths:

- 90 mm
- 140 mm

1.7.1.1 RB with steel front and top plate

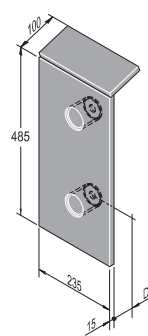

Application

The RB buffer with steel protection front and top plate is designed for vehicles with high lorry beds like interchangeable open bodies and containers.

Available depths:

- 90 mm
- 140 mm

1.7.1.1 RB with steel construction

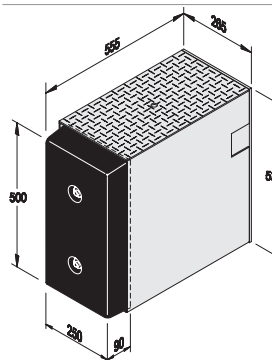

Application

The RB buffer with steel construction is designed to create a security gap between your dock leveler with 1000mm telescopic lip and the truck.

1.7.1.1 RB with steel construction and steel front plate

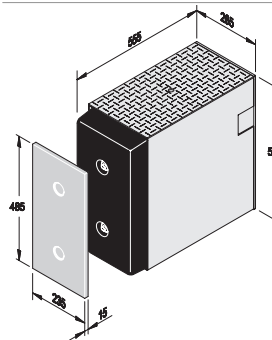

Application

The RB buffer with steel construction is designed to create a security gap between your dock leveler with 1000mm telescopic lip and the truck. The steel protection front plate increases the building protection and the buffer service life.

1.7.1.1 Roller buffer

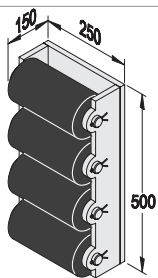

Application

The Roller buffer is a robust solution for docking stations where vehicles make notable vertical movements when loading or unloading. The Roller buffer is designed for vehicles without protruding elements below the rear door.

1.7.1.1.1 EBH

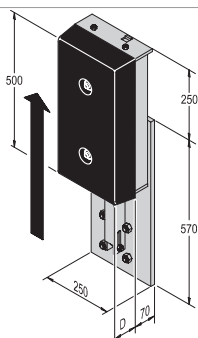

Application

The EBH buffer is the ideal solution for docking stations where vehicles of notable height differences load and unload. This buffer can be vertically adjusted by a 'release device'. Available depths:

- 90 mm
- 140 mm

1.7.1.1.1 EBF

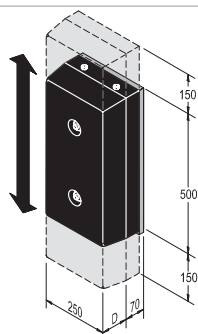

Application

The EBF buffer is the ideal solution for docking stations where vehicles are expected to make notable vertical suspension changes when loading or unloading. This buffer follows vertical movements of the vehicle. Available depths:

- 90 mm
- 140 mm

1.7.1.1 Steel spring buffer 800

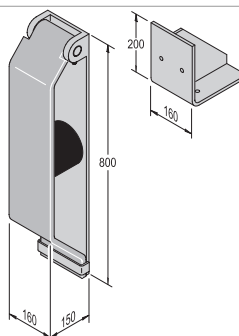

Application

The 800 mm steel spring buffer is designed for applications where vehicles generally are higher than ramp level.

1.7.1.1 Steel spring buffer 600

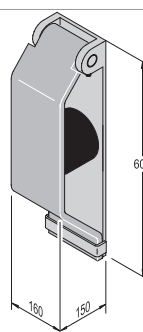

Application

The steel spring buffer is the ideal protector of the ramp as well as the vehicle itself.

1.7.2 ASSA ABLOY DE6190WC Wheel chock

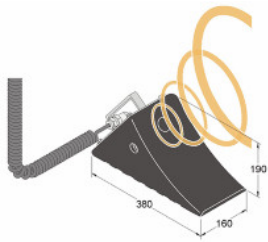

The wheel chock has a sensor to detect the presence and position of the vehicle and is connected to the dock leveler control panel. If no vehicle is detected, the docking station is blocked for safety reasons. Furthermore, the wheel chock prevents the vehicle from moving during loading/unloading.

1.7.3 ASSA ABLOY DE6090TLS Traffic light system



The traffic light system either has a sensor above the dock leveler that measures the presence of the vehicle or it is a wheel chock that detects the vehicle.

If there is no vehicle (dock leveler is free), the traffic light inside is red, outside is green. The traffic light can also be combined with a wheel chock or door/leveler interlocking.

1.7.4 ASSA ABLOY DE6090DL Dock light Heavy Duty LED

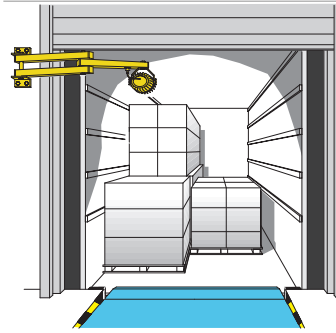

Where dock lights are often a vulnerable object in the docking area, the virtually indestructible Dock Light Heavy Duty LED is the perfect solution to bring light in the truck and docking area. It is designed for the most demanding environments and can withstand possible hard hits from a moving forklift without being damaged.

1.7.5 ASSA ABLOY DE6090FL Fan light

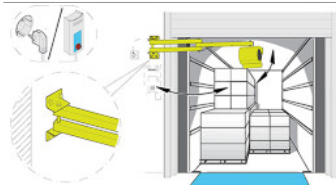

The compact fan light is a combined solution of a fan and a dock light in one system. The fan creates a continuous stream of fresh air that refreshes and cleans the air inside the trailer or container and the integrated dock light provides extensive light. It has a flexible solid arm that fits general industry and logistics applications, for an easy and fast docking process.

1.7.6 Parking guides

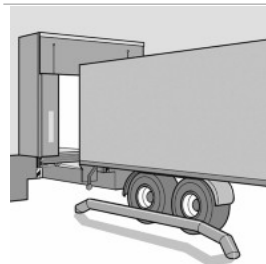

This visual aid makes it easier to park the vehicle and reduces the risk of collision. Especially advantageous for docking stations with wide leveler lips and cushion shelters. Parking guides can be bolted or cast in concrete on the floor before the leveler.

1.7.7 ASSA ABLOY DE6190DI Dock-IN Autodock

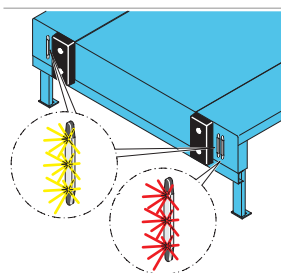

ASSA ABLOY Dock-IN offers a complete line of guide- and traffic lights that align the truck with the docking bay to make the dock-in procedure easy and safe. ASSA ABLOY Dock-IN is based on modern LED technology and stands for high reliability and low energy consumption.

1.7.7.1 Dock-IN White

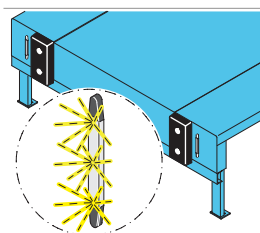

ASSA ABLOY Dock-IN White consists of two white LED light bars. It is designed to help guide a truck to the dock. ASSA ABLOY Dock-IN White offers much more visual aid than white stripes on the shelter or asphalt. Mounted on the wall they are always clearly visible, less exposed to wear and tear and not hidden by dirt and snow!

1.7.7.1 Dock-IN Red

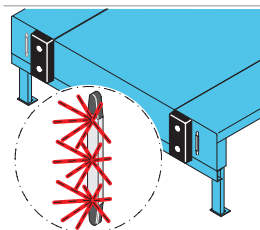

ASSA ABLOY Dock-IN Red is a traffic light system consisting of one red LED light bar, a sensor for truck detection and a traffic light control box. The sensor detects the truck when it is in the right position, very close to the dock. The red LED turns ON to give the signal to the truck driver to break and let the truck roll against the buffer at the lowest speed, without the risk of damage. The system includes interlocking of the loading bay control box functions which are only released when the truck is in place and the red LED is ON.

1.7.7.1 Dock-IN White & Red

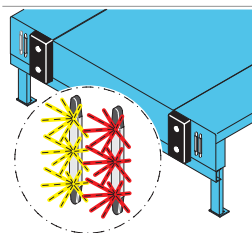

ASSA ABLOY Dock-IN White & Red is the optimum combination of both systems for easy and safe docking. The white LEDs provide the visual target and the red LED positions the truck at the right distance to the dock. The white guiding LEDs turn off when the truck is detected and at the same time the red LED turns ON. Before the truck is leaving, the operator push the RESET button on the control box inside the building. Then the white LEDs turn ON and the red LED turns off as a signal to the truck driver that the loading is finished.

1.7.7.1 Standard

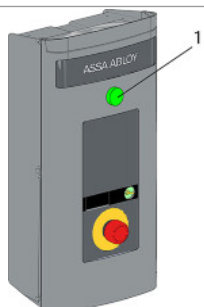

1. Indication light inside and RESET button

Indication Light Inside.

A Green LED light on the 950 control box to indicate that the control box functions are released. The operator of the loading bay equipment knows exactly when he can start loading or unloading. The green LED light will help to save energy and to control the complete loading process.

RESET button

The RESET function is activated from a push button on the control box inside the building before the truck is leaving. The white LEDs turn ON and the red LED turns OFF as a signal to the truck driver that loading is finished. For this function, the leveler must be in parking position, the sectional door closed and the inflatable shelter retracted.

For the activation of the RESET function, you push the button for 1 second. If you push the button for 3 seconds before the truck drives off, then the red LED turns ON again the white LEDs turn OFF. When the truck is leaving, the white LEDs turn ON and the Dock-IN system is ready for the next truck.

1.7.7.1 Available Options

- Dock-IN Green and Red. Green LEDs instead of White. This version has the same function as Dock-IN White and Red.
- Indication Light Inside, built into the 950 control box. A Green LED light on the control box to indicate that the control box functions are released. The operator of the loading bay equipment knows exactly when he can start loading or unloading. The green LED light will help to save energy and to control the complete loading process.
- Second Red LED. A second Red LED can be added to have the red LED traffic light on both sides of the docking bay. This is an option for terminals with left and right hand drive international trucks.
- Wheel chock connection. To increase the safety it is possible to connect the ASSA ABLOY wheel chock to the traffic light function ASSA ABLOY Dock-IN Red or ASSA ABLOY Dock-IN White and Red. The control box will be interlocked until the truck is detected and the wheel chock is in place.

Note:

Make sure the LED bars will not be covered by the Dock shelter.

Lowest possible truck is max. 2000 mm below the sensor position.

1.7.8 Panels for ISO loading system

The ASSA ABLOY DL6120T with lip length 1000 mm can be integrated in an ISO loading system.

Insulated panels are mounted into the pit underneath the dock leveler as part of the ISO loading system. The thickness of the panels (x) is available in 42 or 82 mm.

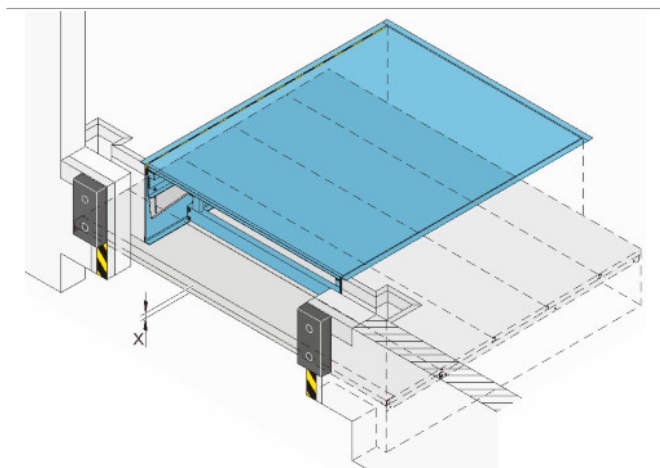

The pit width of the ISO loading system is the dimension (x) underneath the dock leveler.

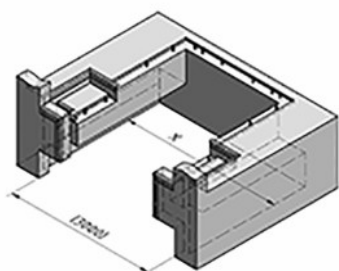

In closed position the ISO loading system secures that the dock leveler is very well sealed off from below, preventing cold or hot air access.

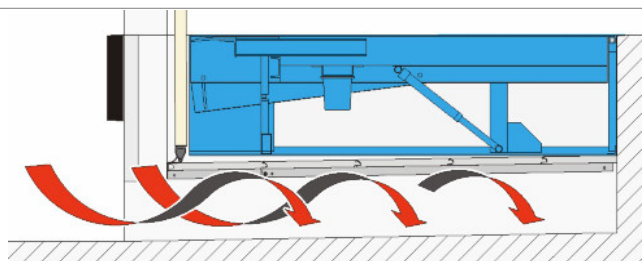

The front part of the panel construction can be folded down to allow access under the dock leveler for service and maintenance work.

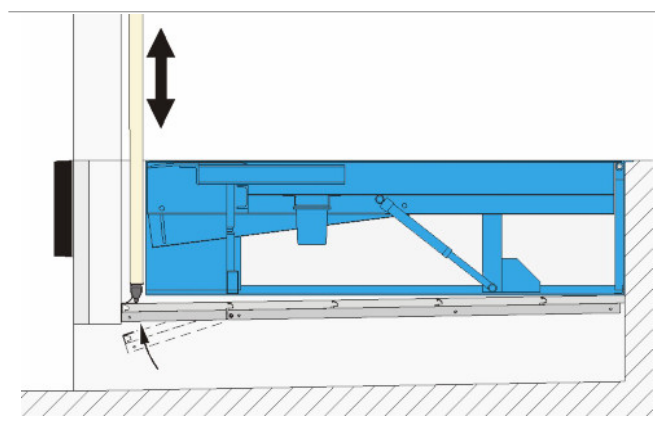

2. Selection guide

2.1 Load capacity according to EN 1398

The EN 1398 describes 3 key definitions about loads.

2.1.1 Rated load

The rated load is the total weight of the goods, the forklift truck and the driver.



2.1.2 Axle load

Axle loads shall be taken acting over two rectangular contact areas at 1 m lateral distance. These areas shall only apply if the actual conditions do not call for more severe loading. The size of the footprint [mm²] is derived from the wheel load [N] divided by 2 [N/mm²]. The ratio of the rectangular print is W:L = 3:2.

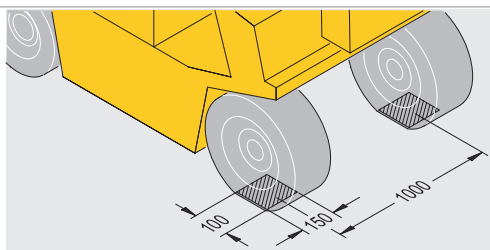

In the drawing measures for a leveler with a load capacity of 100kN or 150kN are shown.

2.1.3 Dynamic load

The dynamic load is the movement of the rated load and is the pressure on the leveler platform caused by the moving forklift truck.

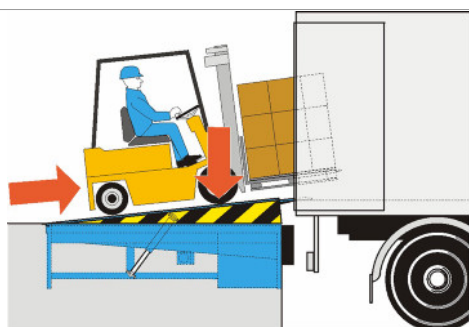

2.2 Select the load capacity

The load capacity of a dock leveler must always be higher than the rated load.

2.2.1 Example

Weight of forklift truck	3600 kg
Weight of goods	1500 kg
Weight of driver	100 kg
Total weight/rated load	5200 kg
Suitable load capacity of the leveler	6000 kg/60kN

The 6 tonnes (60kN) DL6120T teledock is as a standard equipped with a tear plate of 8 mm (8/10).

2.3 Select the leveler length

When determining the leveler length, measure the maximum height difference between the truck bed and the dock level. Next, determine which vehicles will be used and lookup the maximum gradient the vehicles are allowed to be used on.

Vehicle	Max gradient
Roll cage	3%
Hand pallet truck	3%
Electric pallet truck	7%
Forklift truck (battery)	10%
Forklift truck (gas / petrol)	15%

2.3.1 The calculation

Minimal leveler length = height difference / gradient (%)

2.3.2 Example

Vehicle:	Electric pallet truck (max 7% gradient)
Truck height:	1350 – 1000 mm
Dock height:	1150 mm

The difference between Truck height and Dock height = 175 mm

175 mm / 7% = 2500 mm leveler length

2.4 Nominal width

The ASSA ABLOY DL6120T teledock is available with a nominal width of 1750, 2000, 2200 or 2250 mm . The correct nominal width must exceed the widest loading vehicle by at least 700 mm.

2.5 Free space under lip

2.5.1 Steel lip

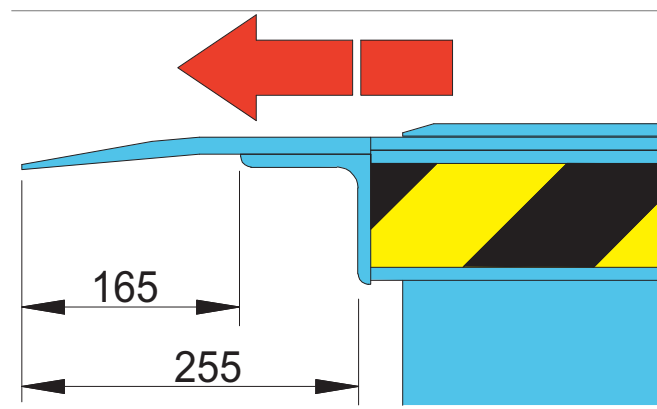

2.5.2 Aluminium lip

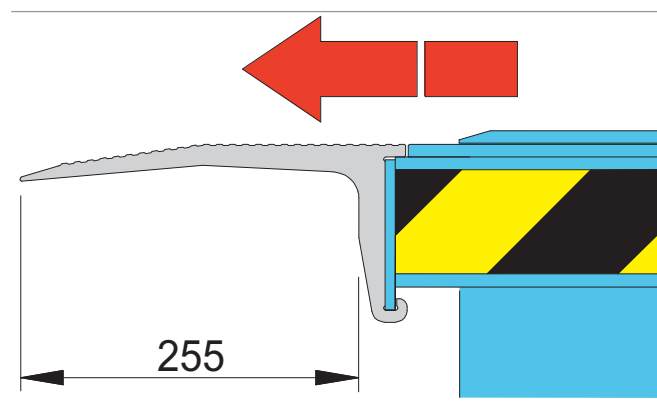

3. Specifications

3.1 Dimensions

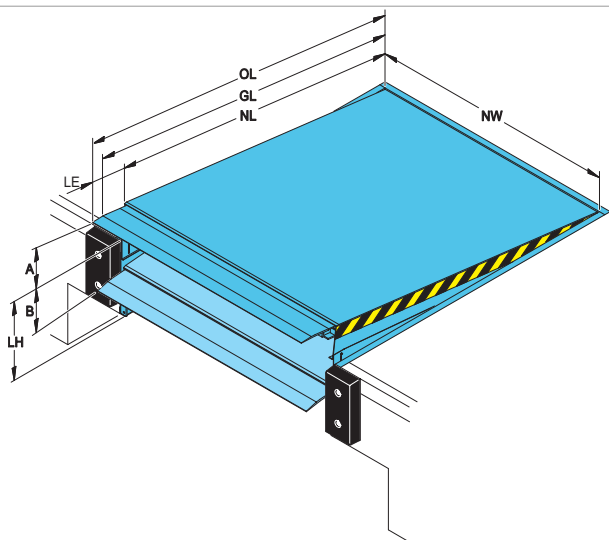

NL	Nominal length
OL	Overall length
GL	Gradient length
NW	Nominal width
LE	Lip extension
LH	Leveler height
A	Working range above dock level
B	Working range below dock level

Dimensions		Vertical working range					
		60 kN					
		LE 500 mm		LE 1000 mm		LE 345 mm	
NL	LH	A	B	A	B	A	B
2000	600	310	310	380	370	270	280
	700	340	400	420	470	310	360
2500	600	420	260	500	290	380	225
	700	430	370	510	420	400	340
3000	600	370	230	430	250	350	210
	800	450	400	520	440	420	360
3500	800	520	400	600	440	490	360
4000	900	590	400	660	440	560	380
4500	900	570	410	640	440	550	380

Nominal width (NW) 1750, 2000, 2200, 2250mm for all sizes.

3.2 Platform thickness

Thickness	Max. point load
8 mm (8/10)	6,5 N / mm ²

3.3 Control units

3.3.1 Dimensions

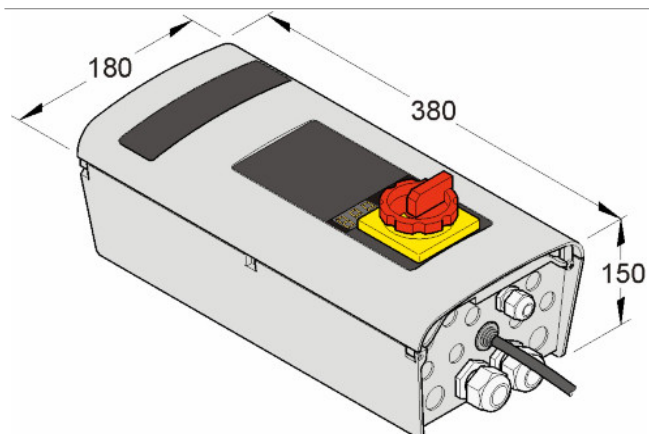

950 Series

3.3.2 Functions

Functions included	LA-TD	DLA-TD	LSA-TD	DLSA-TD
Hold to run button	■	■	■	■
Close (hold to run)	■	■	■	■
Impulse auto button	■	■	■	■
Extend lip (hold to run)	■	■	■	■
Mains isolator	■	■	■	■
Emergency stop button	□	□	□	□
400V	■	■	■	■
230V	□	□	□	
Maintenance indicator	■	■	■	■
3 Digit display	■	■	■	■
Memory function	■	■	■	■
BUS network interface	□	□	□	□
Wheel chock	□	□	□	□
Door control		■		■
Shelter control			■	■

Standard
 Option / Available

4. CEN Performance

4.1 Safety according to the European Standard EN 1398

- Emergency Stop Function.
 - Safety valves block lowering movement after max. 6% of the nominal length of the leveler.
 - Two lift cylinders make sure the leveler stops in a horizontal position.
- Free floating position.
- Platform torsion. Lateral deflection of at least 3% of nominal width.
- Toe guards cover gap between platform and pit in leveler's highest position.
- Working range gradient max. 12,5% (~7°).
- Warning stripes on side plates and on frame (black/yellow).

5. Building and space requirements

5.1 Electrical preparations

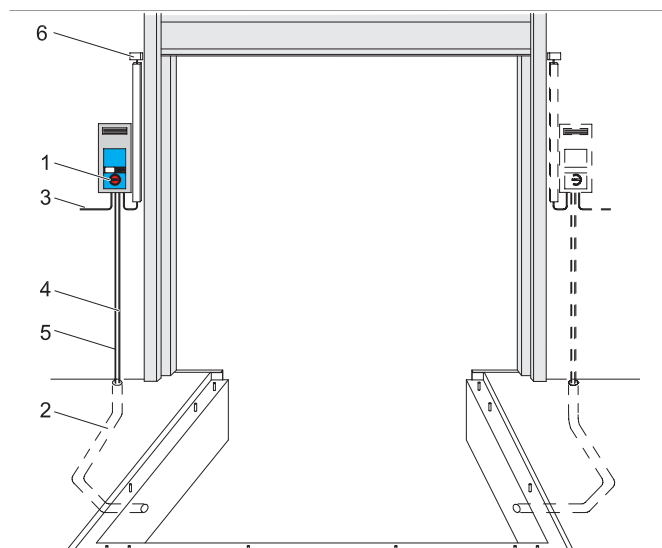

1	Control unit (included in the delivery)
2	Conduit for wiring internal diameter 70, angles <math><45^\circ</math> (by others)
3	Mains supply: 3/N/PE AC 50 Hz Mains fuse: 400V 3-phase, 230V 3-phase Motor power: D0 10 A gL 1,5 kW
4	Cable: 7 x 0,75 mm ²
5	Motor cable: 4 x 1,5 mm ²
6	Optional safety switch on sectional door to disable leveler when door is closed*

*Non standard

5.2 Pit preparations

This section illustrates the required pit preparations for each frame type for the ASSA ABLOY DL6120T teledock.

5.2.1 T - frame + T-frame 200

With tail lift recess

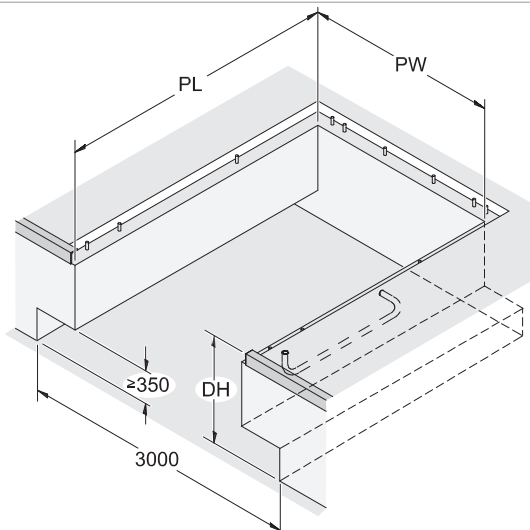

Without tail lift recess

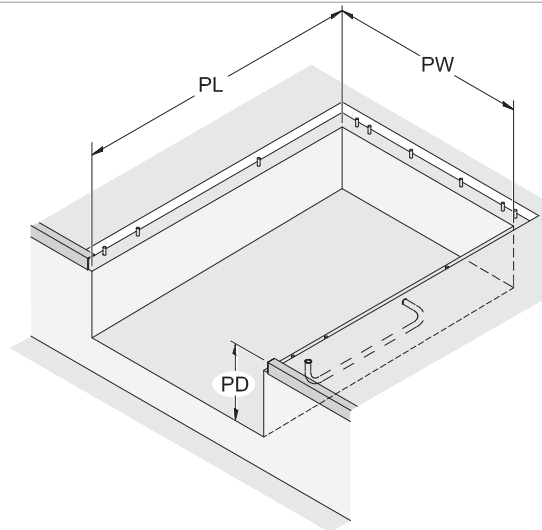

5.2.2 W - frame

With tail lift recess

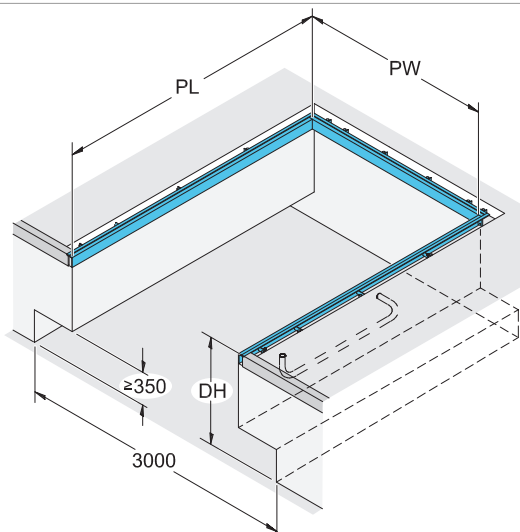

Without tail lift recess

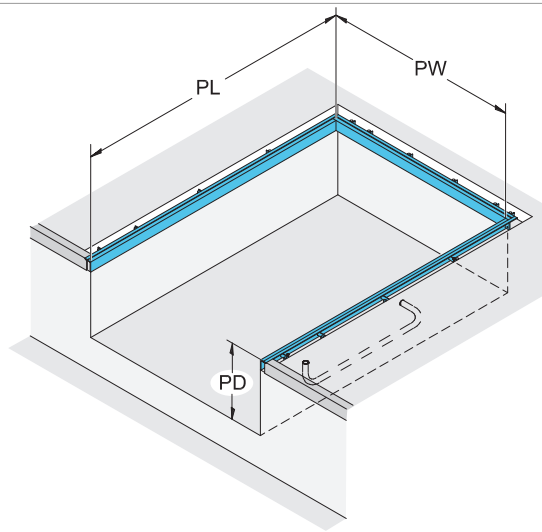

5.2.3 F - frame

With tail lift recess

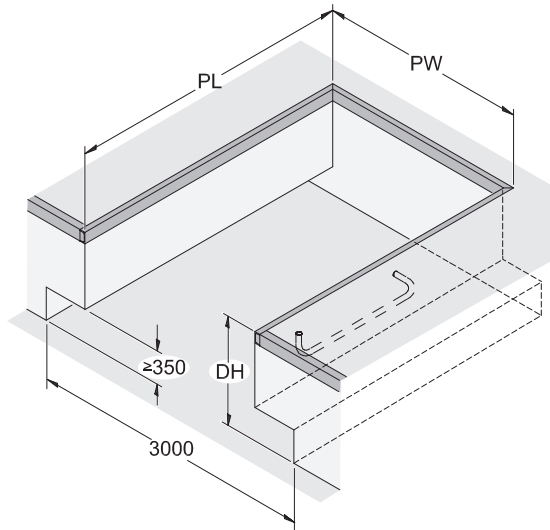

Without tail lift recess

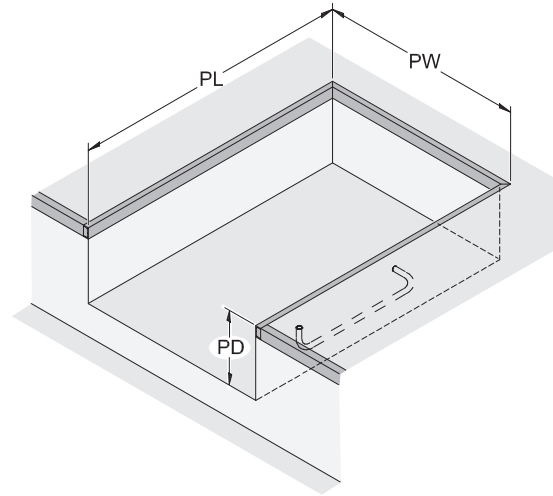

5.2.4 P - frame

With tail lift recess

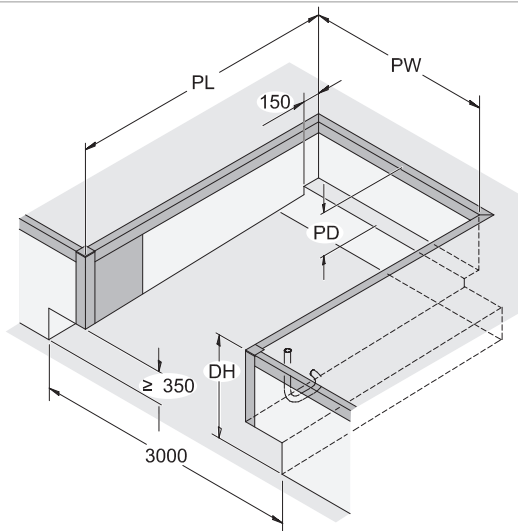

Without tail lift recess

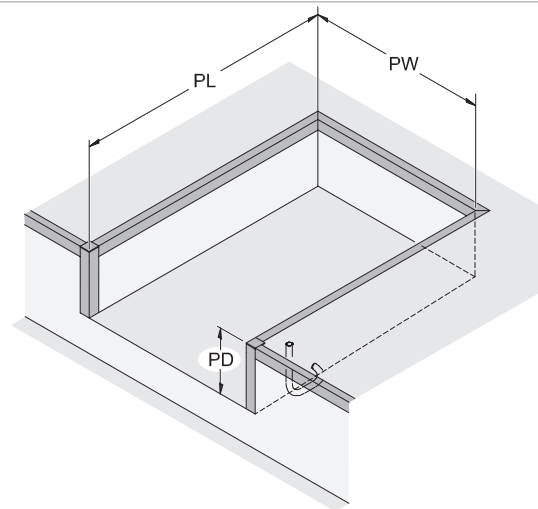

5.2.5 B - frame

With tail lift recess

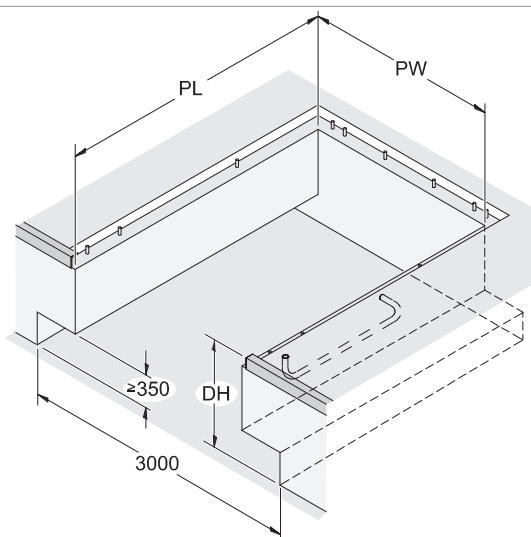

Without tail lift recess

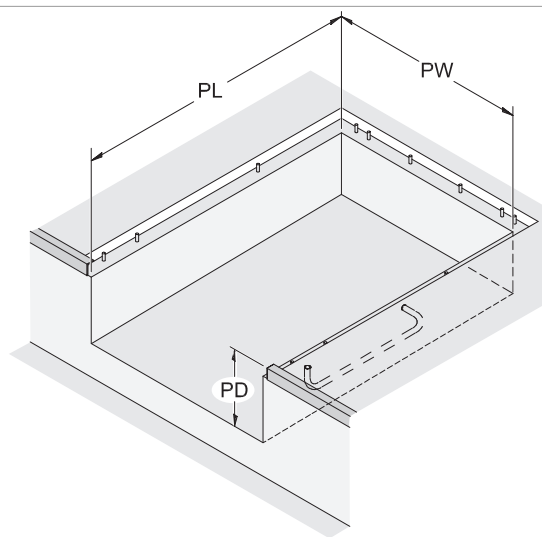

5.2.6 T - frame ISO loading system

General overview ISO loading system

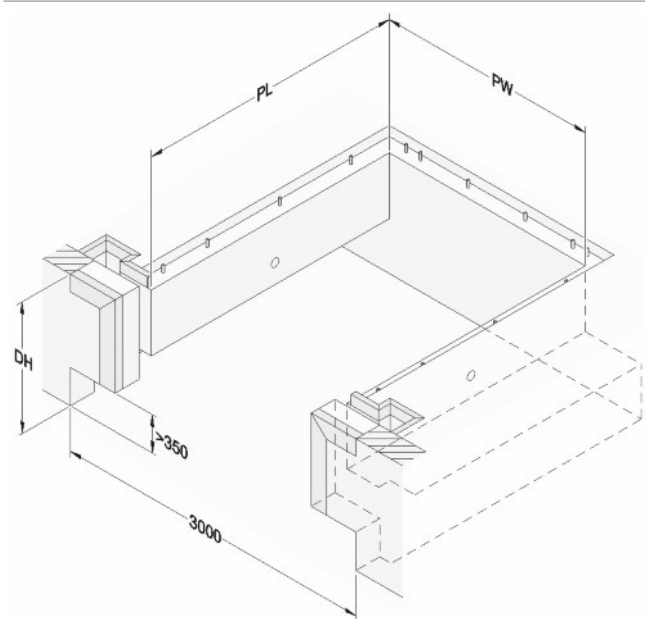

This illustration shows the leveler in parking position. In this position, the insulated overhead sectional door is driven directly onto the horizontal part of the insulation which is installed underneath the dock leveler. The result is perfect sealing. The ASSA ABLOY DL6120T must have a lip length of 1000 mm for this solution. The lip needs to be that long in order to reach the loading vehicle, as the complete dock leveler is installed behind the overhead sectional door of the loading bay.

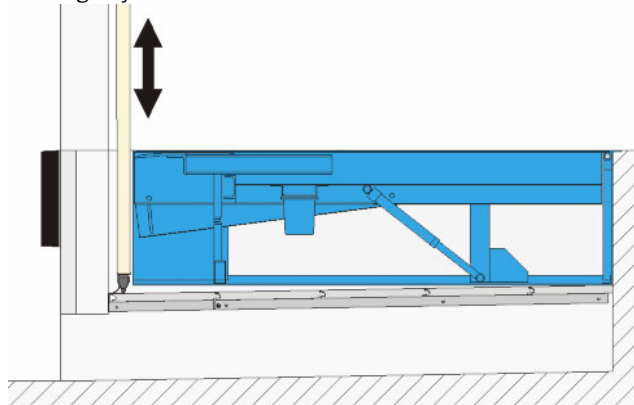

6. Service you can rely on



Gold

The ultimate protection

With full coverage, Gold Service enables you to plan and budget your expenses annually.

- Spare parts for emergency calls
- Labor and travel costs for emergency calls
- Replacement of components according to preventive maintenance schedule and to fulfill legislative and safety requirements

Silver

Added advantages

With cover for all service calls during business hours, Silver Service offers you peace of mind.

- Labor and travel costs for emergency calls
- Preventive maintenance

Bronze

Scheduled Service

With scheduled on site visits, Bronze Service means you know that your doors and docking systems will be regularly serviced and inspected.

- Preventive maintenance

Included in all packages

1-4 scheduled maintenance visits per year	24/7 priority service hotline and fast response	Safety, compliance and quality control checks	Documentation reports provided on site
---	---	---	--

Expert service you can rely on

A healthy business enjoys a steady flow of goods, services and people through its entrances every day. But heavy traffic puts entrances under pressure as every component works to keep them running.

ASSA ABLOY Entrance Systems offer the industry's most complete, flexible service solutions. Because even something as robust and well-engineered as an ASSA ABLOY door or docking system needs to be serviced to stay in great working order.

Pro-active care packages

An ASSA ABLOY service agreement gives you service you can rely on. We have specialized local service technicians on call to take care of your service needs. Equipped with a wide range of spare parts and expertise, to keep your industrial doors and docking systems running.

With an ASSA ABLOY service agreement you can ensure reliable, safe and sustainable operations at every entrance under your agreement, including doors and docking systems, independent of brand.

ASSA ABLOY e-maintenance™ (optional add-on)

For an online overview of your entrance systems and history, add ASSA ABLOY e-maintenance™ to your service package for:

- Easy access to real-time data on all your doors
- Planning, order and service information
- Overview that helps you control lifecycle costs

Index

ASSA ABLOY DE6190DI Dock-IN Autodock..... 16

2

2 retracting tongues..... 7

9

950 Docking DLA TD..... 12

950 Docking DLSA TD..... 12

950 Docking LA TD..... 12

950 Docking LSA TD..... 12

950 Docking power cable..... 12

A

Aluminium lip..... 20

Aluminium telescopic lip..... 7

Application..... 6

ASSA ABLOY DE6090DL Dock light Heavy Duty LED..... 15

ASSA ABLOY DE6090FL Fan light... 15

ASSA ABLOY DE6090TLS Traffic light system..... 15

ASSA ABLOY DE6190WC Wheel chock..... 15

Available Options..... 17

Axle load..... 19

B

B - box-frame..... 11

B - frame..... 27

Bevelled lip..... 7

Buffers..... 13

Building and space requirements.. 24

C

CEN Performance..... 23

Colors..... 9

Control units..... 22

Copyright and Disclaimer Notice... 2

D

Description..... 6

Dimensions..... 21, 22

Dock-IN Red..... 16

Dock-IN White..... 16

Dock-IN White & Red..... 16

Docking control systems..... 12

Dynamic load..... 19

E

EBF..... 14

EBH..... 14

Electrical preparations..... 24

EPDM seal..... 8

Equipment..... 13

Ergonomic lip..... 7

Example..... 19, 20

F

F - flat frame for welding..... 11

F - frame..... 26

Features..... 3

Frames - connection to building.. 10

Free space under lip..... 20

Front cover curtain..... 8

Functions..... 22

G

General..... 6

H

Hot galvanising..... 9

L

Lip material..... 7

Lip shapes..... 7

Lip type..... 7

Load capacity according to EN 1398.. 19

M

Mode of operation..... 6

N

Nominal width..... 20

O

Options..... 6

Overview..... 6

P

P - frame..... 26

P - pit frame for welding..... 11

Paint classes..... 9

Painting..... 9

Panels for ISO loading system..... 18

Parking guides..... 15

Performance..... 3

Pit preparations..... 25

Platform..... 8

Platform tear-plate thickness..... 8

Platform thickness..... 21

R

Rated load..... 19

RB..... 13

RB with steel construction..... 13

RB with steel construction and steel front plate..... 13

RB with steel front and top plate.. 13

RB with steel front plate..... 13

Roller buffer..... 14

RS..... 13

S

Safety according to the European Standard EN 1398..... 23

Select the leveler length..... 20

Select the load capacity..... 19

Selection guide..... 19

Service you can rely on..... 28

Slip protection / noise reduction... 8

Specifications..... 21

Standard..... 17, 6

Standard lip..... 7

Standard paint class..... 9

Standard telescopic lip..... 7

Steel lip..... 20

Steel spring buffer 600..... 14

Steel spring buffer 800..... 14

Steel telescopic lip..... 7

Surface..... 9

T

T - 200 leveler frame for embedding in concrete.....	10
T - frame + T-frame 200.....	25
T - frame ISO loading system.....	27
T - leveler frame for embedding in concrete.....	10
Tapered telescopic lip.....	7
Technical facts.....	3
Telescopic Lip.....	7
The calculation.....	20

W

W - frame.....	25
W - leveler frame for welding.....	10

The ASSA ABLOY Group is the global leader in access solutions.
Every day, we help billions of people to experience a more open world.

ASSA ABLOY
Entrance Systems

ASSA ABLOY Entrance Systems provides solutions for efficient and safe flow of goods and people. Our offering includes a wide range of automated pedestrian, industrial and residential doors, loading dock equipment, perimeter fencing and service.

Follow us:



Please enter ASSA ABLOY Entrance
in the channel's search field.