

Dock leveler

ASSA ABLOY DL6220TR

ASSA ABLOY
Entrance Systems

Experience a safer
and more open world



The dock leveler upgrade solution - for replacement of existing levelers

The ASSA ABLOY DL6220TR Teledock Replacement is a cost-effective upgrade solution to replace obsolete dock levelers. The wide sizes range and the variety of frame designs make it possible to replace existing levelers without any reconstruction. Your expert from ASSA ABLOY will do the visual inspection and find the best solution for your individual situation.

- The ASSA ABLOY DL6220TR Teledock Replacement:
- Preventive maintenance is easy and fast to secure functionality and avoid downtimes.
 - Telescopic lip giving optimal load utilization of the whole vehicle bed area.
 - Larger contact area between vehicle bed and dock leveler.
 - Easy and comfortable operation.
 - Optimal and safe positioning on the vehicle bed.

ASSA ABLOY Insight

Integrated connectivity to enable monitoring, controlling, access door data and features as:

- Equipment performance reliability
- Real time alerts of errors or obstructions
- Operational performance

ASSA ABLOY DE6190DI Dock-IN

ASSA ABLOY Dock-IN is the world's first combined solution with parking guide and traffic lights in one system. ASSA ABLOY Dock-IN ensures a safe and secure dock in procedure with the help of white guiding lights and red traffic lights. There is no need to paint and repaint guiding lines on the asphalt or install conventional steel parking guides, which are an obstacle in the yard. With modern LED technology ASSA ABLOY Dock-IN has a low energy consumption and a long life.

Technical Data

Sizes – pit length	1940 mm – 3030 mm
Sizes – nominal length	1950 mm – 3000 mm
Sizes – pit width	1800 mm – 2305 mm
Sizes – nominal width	1750 mm – 2250 mm
Leveler height	600, 700, 800 mm
Load capacity	60 kN (6 tonnes)
Steel grade all steel parts	S355
Vertical working range	
Rise above dock	up to 530 mm
Fall below dock	down to 470 mm
Platform tear-plate thickness	8/10 mm
Lip type and length	telescopic, 500/1000 mm ergonomic, 345 mm
Lip material	steel or aluminium
Control unit protection class	IP 54
European standard	EN 1398 Dock levelers

Dimensions

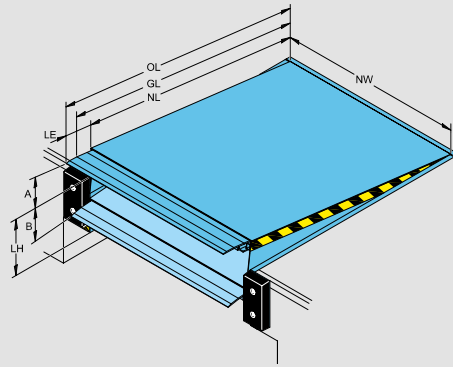

NL	Nominal length
OL	Overall length
GL	Gradient length
NW	Nominal width
LE	Leveler extension
LH	Leveler height
A	Working range above dock level
B	Working range below dock level
DH	Dock height
DW	Door width

Dimensions			Vertical working range		
NL	LH	Measures	500 mm	1000 mm	ERGO
2000	600	A	440	530	400
		B	400	470	370
2500	600	A	450	530	420
		B	380	430	350
3000	600	A	430	490	400
		B	360	410	340

Nominal width (NW) 2000, 2200, 2250 mm for all sizes

Electrical preparations

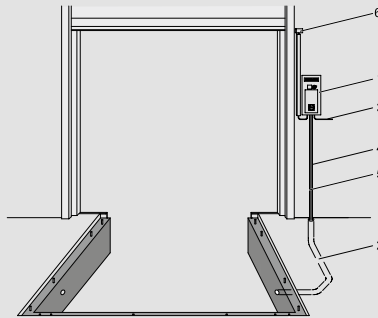

1	Control unit (included in the delivery)
2	Conduit for wiring internal diameter 70, angles <45° (by others)
3	Mains supply: 3 / N / PE AC 50 Hz Mains fuse: D0 10 A gL Motor power: 1,5 kW
4	Cable: 7 x 0,75 mm ²
5	Motor cable: 4 x 1,5 mm ²
6	Optional safety switch on sectional door to disable leveler when door is closed*

*Non standard

Operating functions for Tele lip levelers



ASSA ABLOY DE6190DI Dock-IN

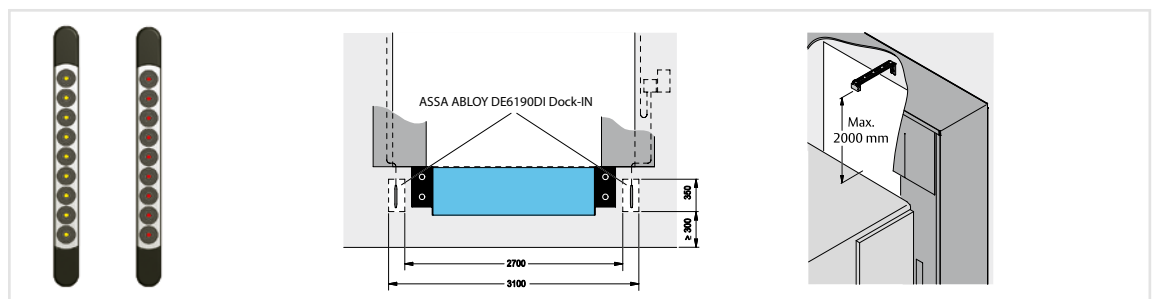

Standard available colors

