

Product datasheet

Overhead sectional door

ASSA ABLOY OH1042P

ASSA ABLOY
Entrance Systems

Experience a safer
and more open world



Copyright and Disclaimer Notice

Although the contents of this publication have been compiled with the greatest possible care, ASSA ABLOY Entrance Systems cannot accept liability for any damage that might arise from errors or omissions in this publication. We also reserve the right to make appropriate technical modifications/replacements without prior notice.

No rights can be derived from the contents of this document.

Color guides: Color differences may occur due to different printing and publication methods.

No part of this publication may be copied or published by means of scanning, printing, photocopying, microfilm or any other process whatsoever without prior permission in writing by ASSA ABLOY Entrance Systems.

Copyright © ASSA ABLOY Entrance Systems AB 2006-2021.

All rights reserved.

ASSA ABLOY, Besam, Crawford, Albany and Megadoor as words and logo are trademarks belonging to the ASSA ABLOY Group.

Technical facts

Features

Max size: (W x H)	8000 x 6000 mm (larger sizes available on request)
Panel thickness:	42 mm
Panel material:	Diamond grid steel or aluminium
Filling:	CFC-free polyurethane, flame retardant DIN 4102-B2
Weight:	Steel: 13 kg/m ² Alu: 10 kg/m ²
Color outside:	14 standard RAL colors
Color inside:	RAL 9002
Track types:	Standard: SL Optional: HL, LL, VL, SLL, HHL
Windows:	Optional: DARP, TARP, DAOP, ALRB, ALBS, Framed section
Passdoor:	Optional: In door leaf with low threshold and standard threshold
Electrical operation:	Optional: Automated operation, Access control, Safety functions

Performance

Opening/closing speed:	CDM9: 0,25 m/s CDM9 HD: 0,18 m/s CDM9 2H: opening 0,5 m/s, closing 0,25 m/s	
Life time expectations:	Door: 200.000 door cycles or 10 years, if service/replacement program is performed Springs: 20.000 door cycles	
Resistance to wind load, EN12424	Insulated panel sections	Class 3 (DLW ≤ 4250) Class 2 (4250 < DLW) (Higher classes on request)
	Framed sections	Class 3 (DLW ≤ 3650) Class 2 (3650 < DLW) (Higher classes on request)
Thermal transmittance, EN12428	1,0 W/(m ² ·K) Steel door, full panel 1,1 W/(m ² ·K) Aluminium door, full panel (Door surface 5000 x 5000 mm, no passdoor) Thermal calculations on exact door sizes and configurations are available on request	
Resistance to Water penetration, EN12425	Class 3 (no passdoor)	
Air permeability, EN12426	Class 3 (no passdoor)	
Acoustic insulation, EN ISO 10140-2	R - 25 dB (no passdoor)	

Contents

Copyright and Disclaimer Notice	2
Technical facts	3
Contents	4
1. Description	7
1.1 General	7
1.2 Dimensions	7
1.2.1 Daylight width and daylight height	7
1.2.2 Section sizes	7
1.3 Door leaf	7
1.3.1 Construction	7
1.3.2 Material	8
1.3.3 Vertical cross-section	8
1.3.4 Colors	9
1.3.5 Seals	9
1.3.6 Wind reinforcement truss	10
1.3.7 Handle	10
1.3.8 Lock bolt	10
1.4 Balancing system	11
1.4.1 Safety devices	11
1.5 CEN Performance	12
1.5.1 Lifetime expectation	12
1.5.2 Resistance to windload	12
1.5.3 Resistance to water penetration	12
1.5.4 Air permeability	12
1.5.5 Thermal transmittance	13
1.5.6 Acoustic insulation	13
1.5.7 Operating forces and safe openings	13
1.6 Track sets	14
1.6.1 General	14
1.6.2 SL - Standard Lift	14
1.6.3 SLL - Standard Lift Low	14
1.6.4 LL - Low Lift	14
1.6.5 HL - High Lift	14
1.6.6 HHL - High lift with spring package at the end of the horizontal track	15
1.6.7 VL - Vertical Lift	15
1.6.8 Special track sets	15

2.	Available Options	16
2.1	Passdoor with low threshold.....	16
2.2	Passdoor with standard threshold (180 mm).....	17
2.3	Fixed sections.....	18
2.3.1	Fixed sections options	18
2.4	Windows.....	19
2.4.1	DARP.....	19
2.4.2	TARP	19
2.4.3	DAOP.....	19
2.4.4	ALRB	19
2.4.5	ALBS.....	19
2.4.6	Protective grating.....	20
2.4.7	Frame section.....	20
2.5	Optional colors*.....	20
2.6	Locks.....	20
2.6.1	Cylinder lock.....	20
2.7	Anti corrosive hardware.....	21
3.	Specifications	22
3.1	Windows and passdoor.....	22
3.1.1	Number of windows.....	22
3.1.2	Windows.....	22
3.1.3	Passdoor Low Threshold	23
3.1.4	Passdoor standard threshold (180mm).....	23
4.	Operating system	24
4.1	Types of operation	24
4.2	Pull-down rope.....	24
4.3	Chain hoist.....	24
4.4	Electrical operation.....	24
4.5	CDM9 Operator - 950 Door control systems	25
4.5.1	CDM9 Operator.....	25
4.6	Selection guidelines for operation type.....	26
4.7	Selection guidelines for door operator	26
4.8	950 Door control system.....	26
4.9	Guidelines for automation.....	26
4.10	Access and automation	27
4.10.1	Basic control functions	27
4.10.2	External control functions.....	27
4.10.3	Automatic control functions.....	27
4.10.4	Safety functions.....	28
4.10.5	Additional functions.....	29

5.	Building and space requirements	30
5.1	Building preparations	30
5.1.1	Installation preparations.....	30
5.1.2	Deflection of door panels	30
5.2	Space requirements	30
5.2.1	Space requirements SL	31
5.2.2	Space requirements SLL	32
5.2.3	Space requirements HL	33
5.2.4	Space requirements HHL.....	34
5.2.5	Space requirements LL	35
5.2.6	Space requirements VL.....	36
6.	Service you can rely on	37
	Index	38

1. Description

1.1 General

The ASSA ABLOY OH1042P overhead sectional door, with its modern, clean design, is one of the most stable and well-insulated overhead doors on the market.

It is an overhead sectional door, suitable for all types of buildings, with regard to both function and appearance. High flexibility makes it possible to install this door in almost every type of building.

The door slides up under the roof when opened, allowing free space around the door opening and leaving the door opening completely free.

The door is made of insulated panels. These panels are designed without thermal bridge to provide minimal thermal transmittance, which reduces energy cost.

The ASSA ABLOY OH1042P overhead sectional door has been designed to meet all operational and safety requirements in the European Directives and the standards issued by the European Standardization Committee, CEN.

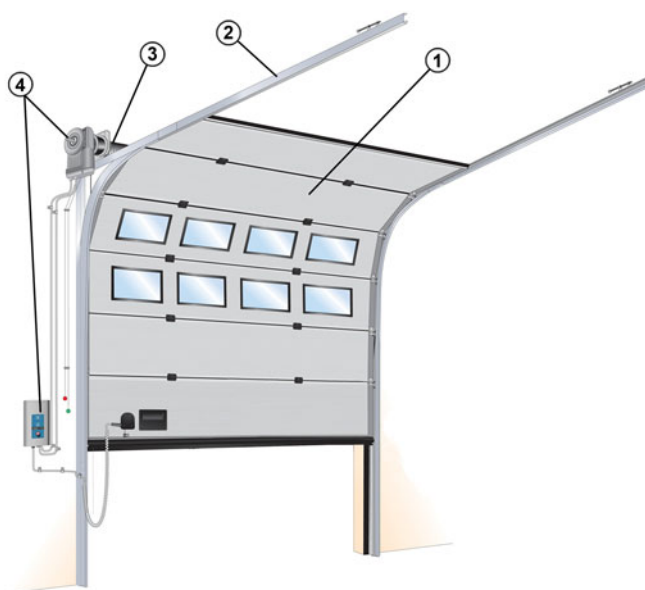

The door has 4 primary parts:

- 1) Door leaf
- 2) Track set
- 3) Balancing system
- 4) Operating system

1.2 Dimensions

1.2.1 Daylight width and daylight height

The standard ASSA ABLOY OH1042P overhead sectional door is delivered in the following size range:

	Daylight width	Daylight height
Min.:	2050 mm	2150 mm
Max.:	8000 mm	6000 mm

Door leaf >550kg, the door will be delivered with 3" track set. On request available up to 10.000 x 6000 mm.

1.2.2 Section sizes

Section height:	545 mm
Top section height:	275 - 820 mm trimcut
Thickness:	42 mm

The door leaf height is achieved by trimcutting the top section.

1.3 Door leaf

1.3.1 Construction

The ASSA ABLOY OH1042P overhead sectional door leaf has horizontal sections, connected together with hinges. The outer hinges of each section have rollers that run in the tracks. The horizontal sections are insulated panels designed without thermal bridges for optimal insulation. The panels are filled with water blown CFC-free polyurethane.

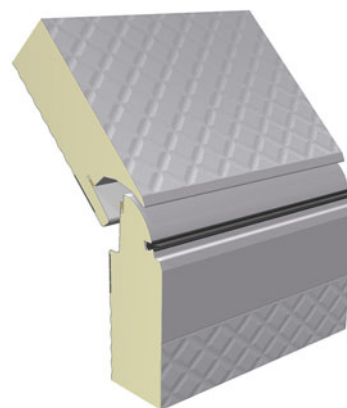

1.3.2 Material

The surface of the door leaf panels is a characteristic diamond grid steel or aluminium sheet. The pre-coated steel panels for the door leaf fulfill outdoor corrosion resistance category RC3 according to EN 10169.

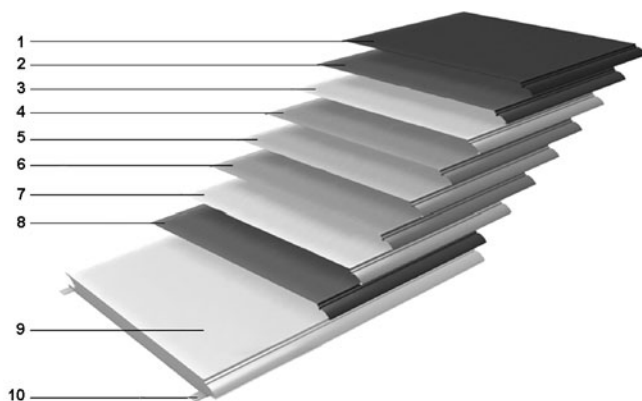

- 1) Polyester coating
 - 2) Primer
 - 3) Chromate layer
 - 4) Zinc based metallic coating*
 - 5) Steel or Aluminium sheet
 - 6) Zinc based metallic coating*
 - 7) Chromate layer
 - 8) Primer
 - 9) CFC-free polyurethane (water blown), Flame retardant DIN4102-B2
 - 10) Reinforcement strips
- *Steel door leaf only. The aluminium door leaf is not coated.

1.3.3 Vertical cross-section

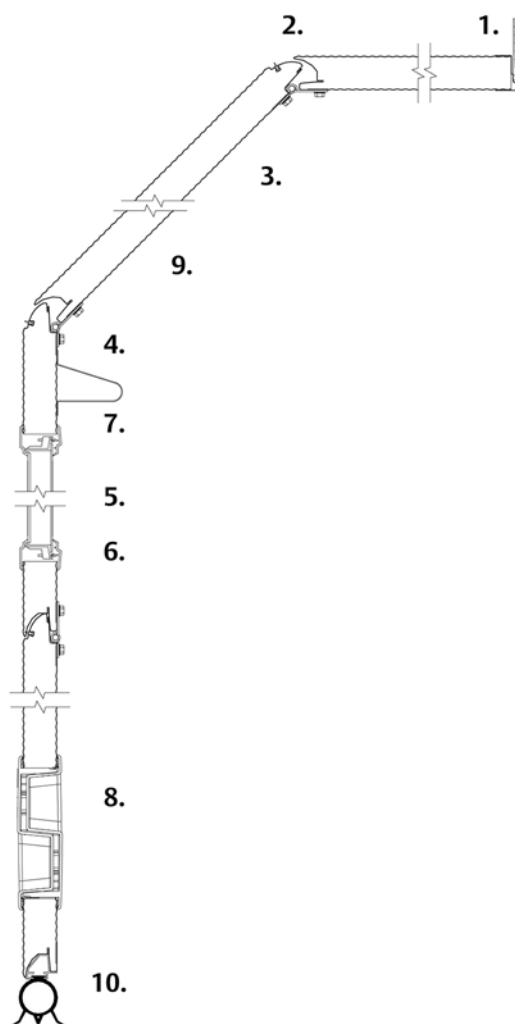

- 1) Top seal
- 2) Section joint with finger pinch protection and seals
- 3) Inner and outer sheet
- 4) Internal steel reinforcement, to provide positive fixing points
- 5) Window (optional)
- 6) High impact polystyrene or aluminium window frame
- 7) Panel truss - wind reinforcement (if necessary)
- 8) Step/lift handle
- 9) Insulation (CFC-free / water blown)
- 10) Bottom seal

1.3.4 Colors

The RAL-colors are as close as possible to the official RAL HR collection. Max. deviation is 1,0 ΔE (RAL 7016 excluded).

Pre-coated range:



RAL 1021



RAL 3000



RAL 5003



RAL 5010



RAL 6005



RAL 7016



RAL 7021



RAL 7024



RAL 8017



RAL 9002

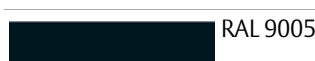

RAL 9005



RAL 9006



RAL 9007

RAL 9010

1.3.4.1 Pre-coated colors

Steel

- Outside color: The steel panel is available in the 14 standard RAL colors.
- Inside color: RAL 9002 - Grey white.

Aluminium

- Outside color: The aluminium panel is available in 3 standard colors: RAL 9006 Aluminium, RAL 5010 - Gentian blue, RAL 9010 - Pure white.
- Inside color: Clear polyester.

1.3.5 Seals

The door is equipped with well designed seals on all sides that gives the door its excellent sealing abilities.

1.3.5.1 Top seal

Installed on the top panel to seal the gap between the panel and the wall. The double lip EPDM rubber top seal is mounted in an ABS adapter profile for optimal insulation and tightness.

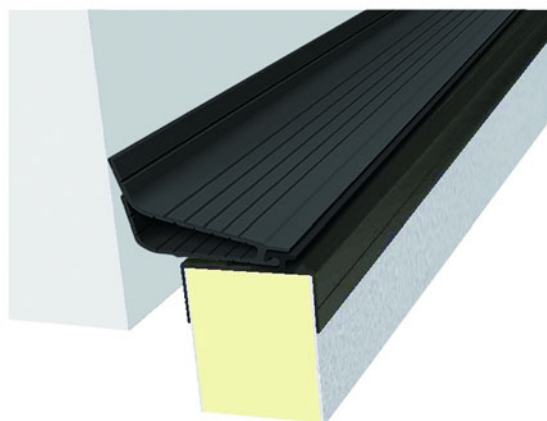

1.3.5.2 Side seal

Installed on the track set to close the gap between the tracks and the door leaf. The double lip side seal design with insulation chambers ensures an optimal insulation and sealing.

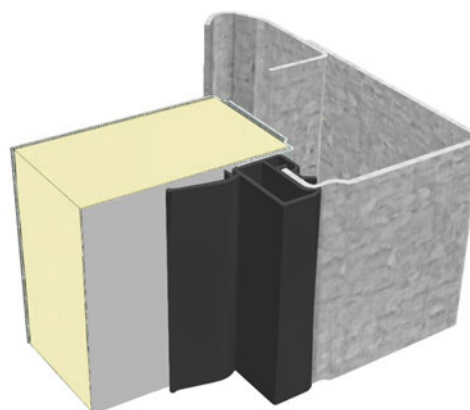

1.3.5.3 Bottom seal

Installed on the bottom edge of the bottom panel, to act as a barrier as well as a shock absorber. The flexible EPDM rubber material and the O-shape provides continuous pressure on the floor, ensuring maximum sealing. The bottom seal is mounted in an ABS adapter for optimal insulation and reduced risk of condensation.

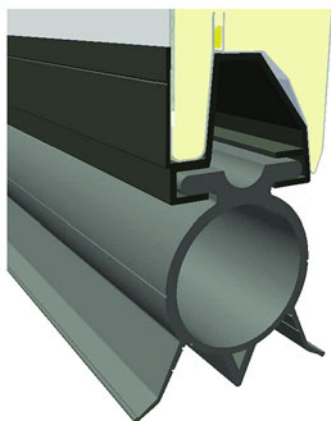

1.3.6 Wind reinforcement truss

Wider door panels and panels with windows are reinforced with metal profiles that act as trusses. These trusses reduce bending of the panel caused by wind loads or when the door leaf is in the horizontal position and is bending under its own weight.

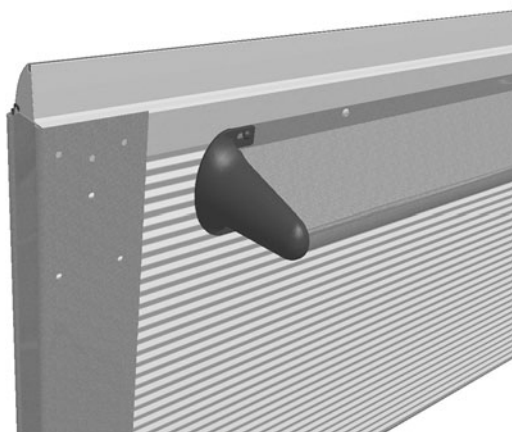

1.3.7 Handle

For manual operation, every ASSA ABLOY OH1042P overhead sectional door is provided with a solid, easy to grip and step-on handle, finished with the ASSA ABLOY logo.



1.3.8 Lock bolt

A standard ASSA ABLOY OH1042P overhead sectional door is equipped with a lock bolt. The lock bolt locks the door from the inside, without the use of a key. The lock bolt has a hole in the latch, to allow the use of a 12mm padlock.

The lock bolt is not visible from the outside.

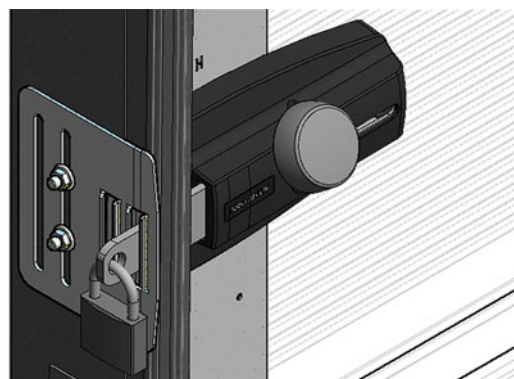

1.4 Balancing system

The balancing system balances the door by applying a force nearly equal to the weight of the door leaf. This allows the door leaf to be moved up and down manually, and to stay open in any position.

The system is installed on the top or the end of the track set and works as follows: Two torsion springs are installed on a shaft above the door opening. This shaft has a cable drum on each end from which door cables run to the bottom corners of the door leaf. Turning the shaft moves the door up or down.

1.4.1 Safety devices

The balancing system supports heavy forces. In case of a spring or cable break, its counterforce is lost. The door is therefore equipped with two safety devices that can block downward door movement:

- Spring Break Device (standard)
- Cable Break Device (optional)

1.4.1.1 Spring break device (SBD)

The Spring Break Device (SBD) is delivered with all ASSA ABLOY OH1042P overhead sectional doors.

In the event of a spring break, the sudden drop force activates the Spring Break Device (SBD). The shaft will be locked in less than 300 mm of door movement.

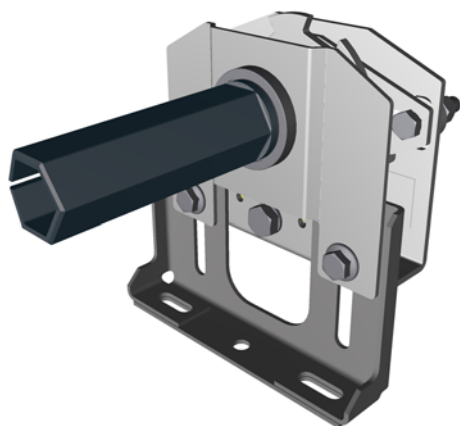

1.4.1.2 Cable break device (CBD)

The Cable Break Device (CBD) is an optional safety device. In the event of a cable failure the door leaf will be blocked in less than 300 mm to avoid damage.



1.5 CEN Performance

1.5.1 Lifetime expectation

Door: 200.000 door cycles or 10 years, if service/replacement program is performed

Springs: 20.000 door cycles

1.5.2 Resistance to windload

EN12424	Without passdoor
Test result	Class 3

Class	Pressure Pa (N/m ²)	Specification
0	-	No performance determined
1	300	
2	450	
3	700	
4	1000	
5	> 1000	Exceptional : Agreement between manufacturer and supplier

1.5.3 Resistance to water penetration

EN12425	Without passdoor
Test result	Class 3

Class	Pressure Pa (N/m ²)	Specification
0	-	No performance determined
1	30	Waterspray for 15 minutes
2	50	Waterspray for 20 minutes
3	> 50	Exceptional : Agreement between manufacturer and supplier

1.5.4 Air permeability

EN12426	Without passdoor
Test result	Class 3

Class	Air permeability dp at a pressure of 50 Pa (m ³ /m ² /h)
0	-
1	24
2	12
3	6
4	3
5	1,5
6	Exceptional : Agreement between manufacturer and supplier

1.5.5 Thermal transmittance

EN12428

Thermal transmittance	1,0 W/(m ² ·K) Steel door, full panel 1,1 W/(m ² ·K) Aluminium door, full panel
-----------------------	--

(Door surface 5000mm x 5000mm, no passdoor)

1.5.6 Acoustic insulation

ISO 10140-2

Acoustic insulation *	R - 25 dB
-----------------------	-----------

* Door surface 4.000 x 2.500 mm, no passdoor (for other sizes it can differ)

1.5.7 Operating forces and safe openings

EN12453 & EN12604	Crushing force N	Crushing force N	Crushing force N
Opening gap mm	200 mm from lateral border right from outside	In the middle of the door opening	200 mm from lateral border left from outside
50 mm	passed	passed	passed
300 mm	passed	passed	passed

The crushing force is the force needed for the safety edge to be activated. The maximum force allowed, according to EN12453 safety in use of power operated doors is 400 N within a maximum period of time of 0.75s. With standard light curtain there is no crushing force.

1.6 Track sets

1.6.1 General

The track set supports the door leaf on its rollers and guides it upwards. The selection of the appropriate track set is based on various factors:

- Available head room
- Door height
- Type of vehicles
- Presence of roof obstructions, pipes and overhead crane beams.

The track sets below cover most applications. Other applications are available on request.

1.6.2 SL - Standard Lift

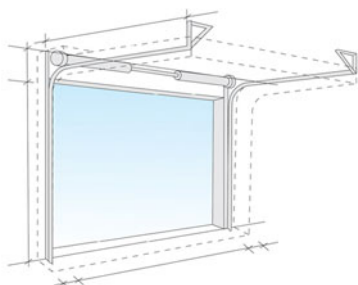

- Building type: Most standard industrial buildings.
 - Benefits: Optimal design for common buildings.
- The Standard Lift track set, with the spring package just above the door, is the most common solution

1.6.3 SLL - Standard Lift Low

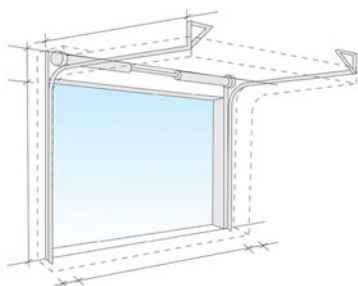

- Building type: Low ceilings.
- Benefits: Achieve more daylight height with a limited head room.

The Standard Lift Low track set is a variant of the Low Lift where the spring package is installed just above the door.

1.6.4 LL - Low Lift

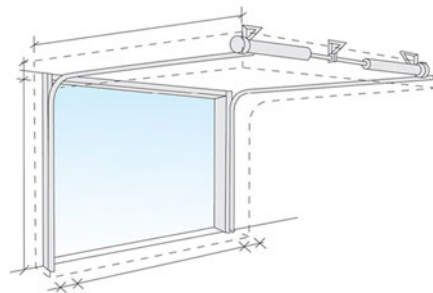

- Building type: Low ceilings.
- Benefits: Achieve maximum daylight height with minimum head room.

Same as standard lift, but with the spring package at the end of the horizontal tracks.

1.6.5 HL - High Lift

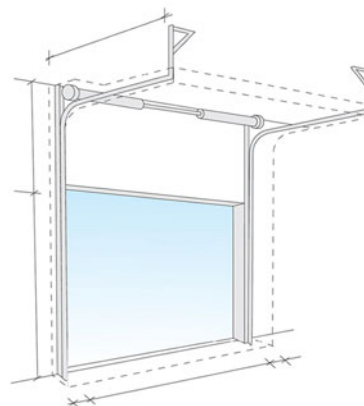

- Building type: High ceilings. On the High Lift track set the spring package is placed high above the door.
- Benefits: This track type allows high vehicles to cross along the door opening without obstructions of the horizontal tracks.

This track type is used when the space above the door is considerable, and is needed for work and traffic, e.g.: high vehicles.

1.6.6 HHL - High lift with spring package at the end of the horizontal track

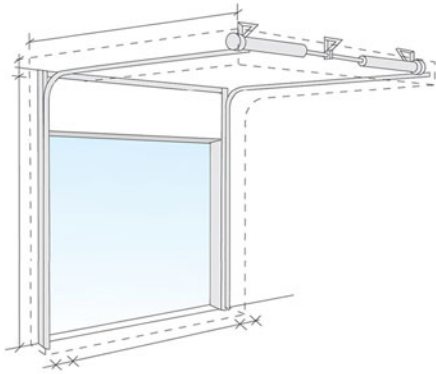

- Building type: High ceilings. Used when space between ceiling and lower edge of horizontal track is limited.
 - Benefits: Achieve maximum highlift with minimum head room.
- High lift hardware with the spring package placed in the end of the horizontal track.

1.6.7 VL - Vertical Lift

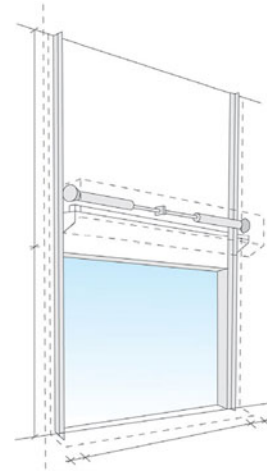

- Building type: Very high ceiling and high working space requirements.
- Benefits: Allows high vehicles to cross along the door opening without any obstructions.

If the space between the daylight height and the roof is sufficient, with this track type, the door can be opened vertically.

1.6.8 Special track sets

The ASSA ABLOY OH1042P overhead sectional door track set can be custom designed to make the door fit in places that seem quite impossible. Our door technicians can solve installation problems where the door must share space with ventilation systems, crane beams, etc. For example:

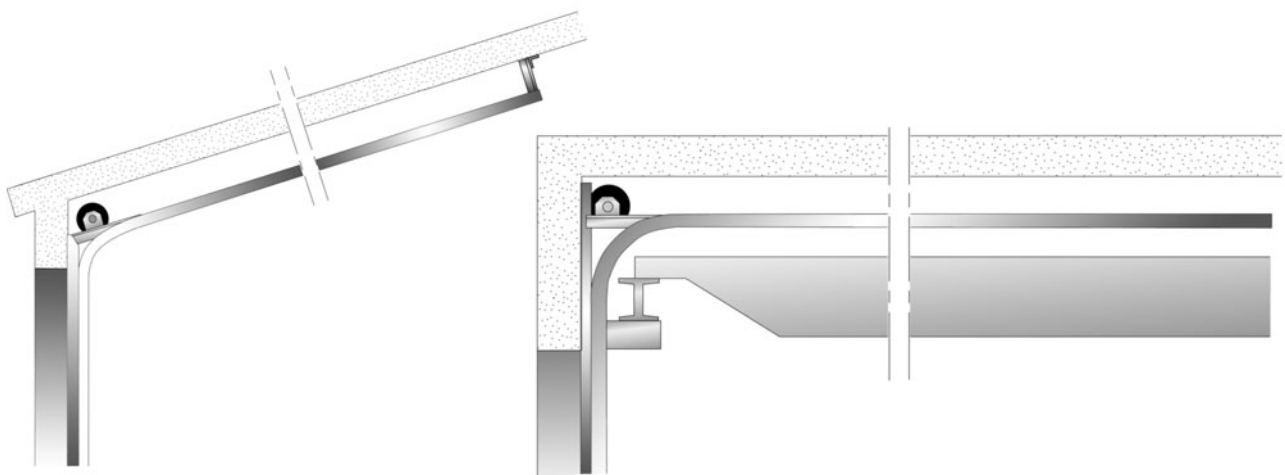

2. Available Options

2.1 Passdoor with low threshold

The passdoor with low threshold is designed to optimize comfortable pedestrian passing and minimizes the risk of tripping. In addition, with the sturdy design of the bottom profile it is not required to strengthen the door leaf with a bottom reinforcement truss.



Features:

- 900 mm free passing space
- Free passing height 2056 mm
- Always opening outwards, min. 90 degrees opening
- Hinged left or right
- Seals in passdoor frame reduce air permeability.
- Integrated passdoor switch if electrically operated
- Aluminium door handle
- All commonly used cylinder locks are available:
Euro, Keso. Standard : Euro cylinder lock
- High quality door closer
- Panic lock (option)
- Minimum DLH 2261 mm

Construction

This passdoor is designed with a sturdy and wide aluminium profile. This profile is ribbed, minimizing the risk of slipping when there is rain or snow on the floor or on the profile.

At passdoor

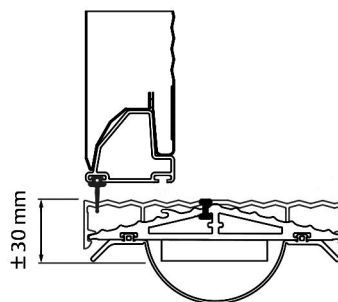

Beside passdoor

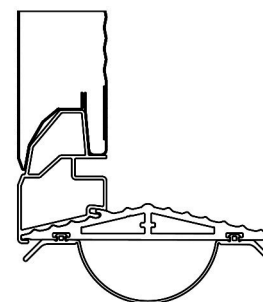

Outside view of threshold



Types of operation

The low threshold passdoor is available for all types of operation. In case of impulse-down button operation, a special CDM9 with 950 control unit is required with in front running photocells that detect persons and objects in the door opening when the door closes.

2.2 Passdoor with standard threshold (180 mm)

The standard 180 mm is designed to be combined with virtually all options of the door. It is not applicable as an emergency exit, with a threshold of 180 mm.



Features:

- 900 mm free passing space
- Free passing height 2046 mm
- Always opening outwards, min. 90 degrees opening
- Hinged left or right
- Seals in passdoor frame reduce air permeability.
- Integrated passdoor switch if electrically operated
- Aluminium door handle
- All commonly used cylinder locks are available:
Euro, Keso. Standard : Euro cylinder lock
- High quality door closer
- Panic lock (option)
- Minimum DLH 2261 mm

Construction

This passdoor is constructed with the standard bottom section and bottom seal. A reinforcement truss on the bottom section is required to maintain the door's sturdiness and resistance to wind load.

At passdoor

Beside passdoor

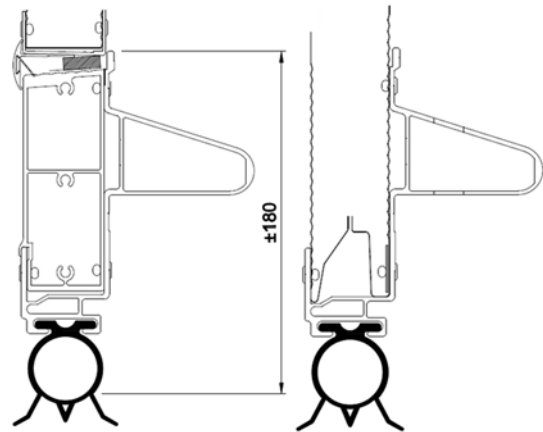

Outside view of threshold



2.3 Fixed sections

Fixed sections can advantageously fill space around new doors that are smaller than the wall opening. Fixed sections are available in top and side sections. Fixed sections are supplied in the same color and construction as the door leaf. A fixed section can be provided with a passdoor for two reasons: Safety and energy cost reduction.

- Safety: Putting a separate passdoor in a fixed section next to the industrial door separates pedestrian and vehicle traffic.
- Energy cost reduction: The opening space for frequent pedestrian traffic is minimized.

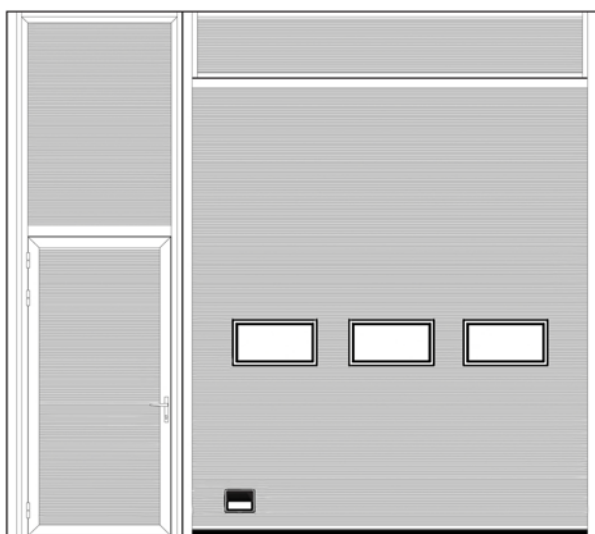

2.3.1 Fixed sections options

	Minimum size in mm (Daylight width - Daylight height)
Passdoor	800 - 2076
Side panel with passdoor (A)	800 - 2441
Side panel with passdoor (B)	1496 - 2076
Side panel with passdoor (C)	1496 - 2441
Side panel without passdoor	300 - 300
Side panel without passdoor (loose sections)	83 - 140
Top panel (loose sections)	83 - 83

Maximum size in mm (Daylight width - Daylight height)

Passdoor	1495 - 2440
Side panel with passdoor (A)	1495 - 6000
Side panel with passdoor (B)	2400 - 2076
Side panel with passdoor (C)	2400 - 6000
Side panel without passdoor	2400 - 6000
Side panel without passdoor (loose sections)	8000 - 6000
Top panel (loose sections)	8000 - 6000

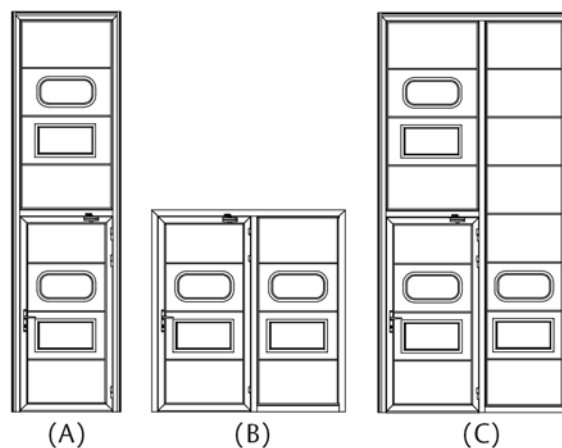

B - C available on request

2.4 Windows

The door sections can be glazed with windows*. The number of windows per section is directly related to the daylight width. Optionally, one single window can be placed on the outer left or right side, in the third section.

*The bottom section cannot be glazed.

2.4.1 DARP

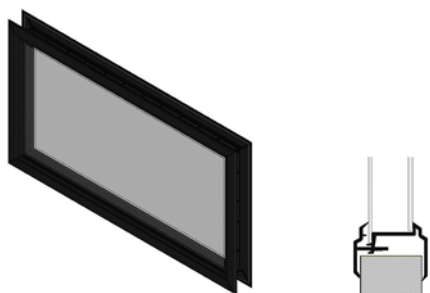

- Double layer Acrylic (3 + 2 mm), Rectangular, in Plastic frame
- Light opening: 604 x 292 mm
- Window frame: Black

2.4.2 TARP

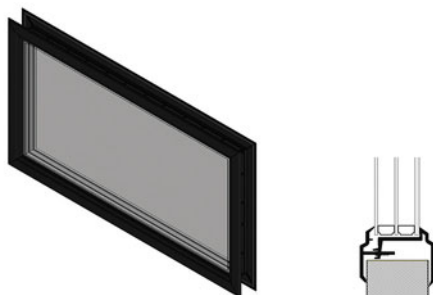

- Three layer Acrylic (3 + 3 + 2 mm), Rectangular, in Plastic frame
- Light opening: 604 x 292 mm
- Window frame: Black

2.4.3 DAOP



- Double layer Acrylic (3 + 2 mm), Oval, in Plastic frame
- Light opening: 610 x 292 mm
- Window frame: Black

2.4.4 ALRB



- Aluminum Layer Rectangular Burglar, double layer (6+6 mm) in aluminum frame
- Light opening: 578,5 x 268,5 mm
- Burglar Resistance Class 2

2.4.5 ALBS



- Aluminum Layer Burglar Small, double layer (6+6 mm) in aluminum frame
- Light opening: 578,5 x 146,5 mm
- Burglar Resistance Class 2

2.4.6 Protective grating

To discourage burglars to use the windows as a way in, protective window grating can be installed on the inside of the door. Standard delivery is dull black. Other colors available on request. The protective window grating measures 750 mm width. The height depends on the height of the section.



2.4.7 Frame section

The ASSA ABLOY OH1042P overhead sectional door can be fitted with a ASSA ABLOY OH1042F frame section. The height of this section is 545mm. Please refer to ASSA ABLOY OH1042F documentation for details.



2.5 Optional colors*

Factory painting

The door leaf can be factory painted in any RAL and NCS color plus some metallic colors, outside only. The painting can be applied to only the panel or to the complete door leaf, including frames and strips.

Panel only

Complete

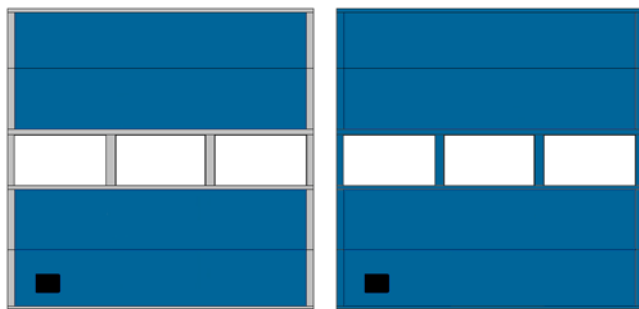

* Other colors available on request

2.6 Locks

2.6.1 Cylinder lock

The Cylinder lock is a key operated lock which offers extra security. The lock is installed on the inside and can be unlocked with a key and turning the handle. Access to the Cylinder lock is possible from either only the inside, or both the inside and the outside.



2.7 Anti corrosive hardware

For use under harsh conditions the ASSA ABLOY OH1042P overhead sectional door can be fitted with a set of anti corrosive hardware. There are 3 sets available to cope with the different demands.

Set Corrosive C

Roller brackets	Stainless steel
Rollers	Stainless steel
Clamp	Stainless steel
Hinges, Joining plate	Plastic
Screws	Stainless steel
Corner bracket	Powder coated
Door cables 3-5 mm	Stainless steel

Set Corrosive A

All options in Set Corrosive C plus:

End caps	Powder coated
Top section brackets	Powder coated
Trusses	Powder coated
Track set	Powder coated
Screw/bolt set	Stainless steel

Set Corrosive Z

Springs 95mm or 152mm	Zinc electroplated
-----------------------	--------------------

Recommended for wet environments like Carwash.

The anti corrosive hardware sets are available for the track types SL, SLL, HL, HHL, LL and VLB.

VLA and VLT are available in set C only .

The max. doorweight for anti corrosive hardware is 410 kg and the max. daylight width is 8.000mm. For technical reasons some parts are not available in an anti corrosive version.

3. Specifications

3.1 Windows and passdoor

3.1.1 Number of windows

For windows and passdoors, the daylight width is divided into a fixed grid. The number of windows depends on the daylight width of the door and the presence of a passdoor.

Windows

No.	Daylight width of windows (without Passdoor)	Daylight width (with Passdoor)
1	2050 - 2134 mm	2050 - 2299 mm
2	2135 - 2999 mm	2300 - 3264 mm
3	3000 - 3864 mm	3265 - 4229 mm
4	3865 - 4729 mm	4230 - 5194 mm
5	4730 - 5594 mm	5195 - 6050 mm
6	5595 - 6459 mm	
7	6460 - 7324 mm	
8	7325 - 8000 mm	

Optional: One window in the outer left or right side of section 3 only.

3.1.2 Windows

Without Passdoor

DARP/TARP/ALRB/ALBS

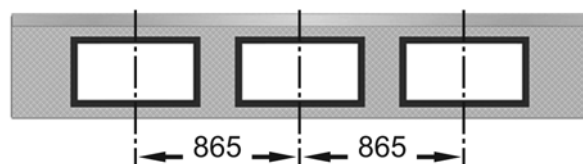

DAOP

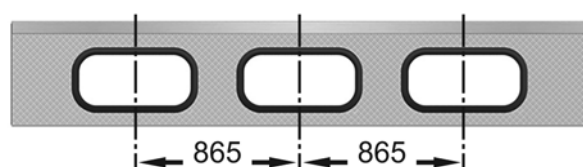

With Passdoor

DARP/TARP/ALRB/ALBS

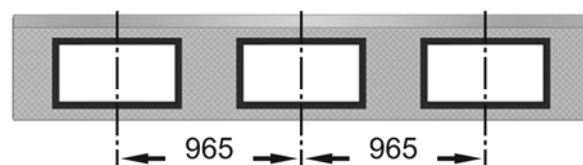

DAOP

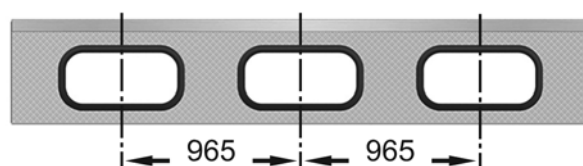

3.1.3 Passdoor Low Threshold

Passdoor opening sizes

Width:	900 mm
Height from floor level:	2080 mm

Position of passdoor *

Daylight width	Pane no.
2050 - 2299 mm	1
2300 - 3264 mm	1 or 2
3265 - 4229 mm	2
4230 - 5194 mm	2 or 3
5195 - 6050 mm	3

* In case framed section(s) are included, a passdoor is not possible in the outer panes for construction reasons.

* Position and opening direction of the passdoor depend on the total door width and glass weight. For detailed information contact your local sales team.

Permissible overhead door sizes

Minimum permissible DLW	2050 mm
Maximum permissible DLW	6050 mm
Minimum permissible DLH	2261 mm
Maximum permissible DLH	6050 mm

Specifications

Threshold height:	30 mm incl. bottom seal
Lock:	Depends on market

3.1.4 Passdoor standard threshold (180mm)

Passdoor opening sizes

Width:	900 mm
Height from floor level:	2090 mm

Position of passdoor *

Daylight width	Pane no.
2050 - 2299 mm	1
2300 - 3264 mm	1 or 2
3265 - 4229 mm	2
4230 - 5194 mm	2 or 3
5195 - 6050 mm	3

* Position and opening direction of the passdoor depend on the total door width and glass weight. For detailed information contact your local ASSA ABLOY sales team.

Permissible overhead door sizes

Minimum permissible DLW	2050 mm
Maximum permissible DLW	6050 mm
Minimum permissible DLH	2261 mm
Maximum permissible DLH	6050 mm

Specifications

Threshold height:	180 mm incl. bottom seal
Lock:	Depends on market

4. Operating system

4.1 Types of operation

The ASSA ABLOY OH1042P overhead sectional door can be opened and closed manually. They are also prepared for electrical operation. Electrically operated doors can be controlled by hand or be fully automatic. Traffic frequency, climate requirements and the weight of the door play a key role in choosing the optimal control system.

4.2 Pull-down rope

The ASSA ABLOY OH1042P overhead sectional door can be operated manually with a pull-down rope. The pull-down rope is directly connected to the door leaf.

4.3 Chain hoist

For heavier doors, a chain hoist allows easier door operation. There are three types of chain hoist:

D-hoist:



- D-hoist: Non-geared chain transmission directly connected to the shaft. Recommended for doors up to 250 kg (For hexagonal shaft only).

T-hoist:

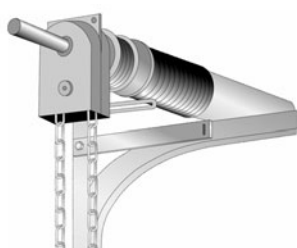

- T-hoist: Geared (ratio 1:4) chain transmission directly connected to the shaft. Recommended for doors up to 250 kg (For all shaft types).

U-hoist:



- U-hoist: Geared (ratio 1:3) indirect chain transmission. Recommended for doors of 250 up to 400 kg (For all shaft types).

4.4 Electrical operation

The ASSA ABLOY OH1042P overhead sectional door can be supplied or upgraded with an electrical operating system (mandatory if door weight > 400 kg). Electrical operation gives access to the full program of Access and Automation functions, that can fulfill many operational needs, related to traffic type and frequency, door weight and temperature control.



4.5 CDM9 Operator - 950 Door control systems

The CDM9 operator is a combination of the CDM9 operator and the 950 door control system. The regular CDM9 model is available for doors up to 400 kg. The CDM9 HD model is available for doors up to 800 kg. The double speed CDM9 2H model is available for doors up to 250 kg.

If a door weighs over 550kg, the CDM9 should be equipped with an integrated geared (ratio 1:3.5) chain hoist:

4.5.1 CDM9 Operator

One main part of the system is the operator: an electric motor which drives the balancing shaft with the cable drums and torsion springs. It can be retrofitted to an already installed door. The CDM9 operator is mounted directly on the balancing shaft and does not require any special wall reinforcement.



Key features:

- Smooth and silent
- Soft start and stop
- Fits all track types and shafts
- Life time: 84.000 - 300.000 door cycles (depending on weight and temp.) e.g.:
 - temp. 0 °C - +40 °C/weight 250 kg = 300.000 cycles
 - temp. -20 °C - +60 °C/weight 400 kg = 84.000 cycles

	CDM9	CDM9 HD	CDM9 2H
Voltage supply: +/- 10%	230V AC 1-phase 50/60Hz	230V AC 1-phase 50/60Hz	230V AC 1-phase 50/60Hz
Power:	0,37 kW	0,6 kW	0,37 kW
Degree of protection:	IP65, with connector IP44	IP65, with connector IP44	IP65, with connector IP44
Allowed door weight, max.:	400 kg	800 kg	250 kg
Temperature working range:	-20 °C to +55 °C*	-20 °C to +55 °C*	-20 °C to +55 °C*
Operating factor:	ED = 30% S3 10 min. intermittent	ED = 30% S3 10 min. intermittent	ED = 30% S3 10 min. intermittent
Mounting preparations:	-	When installing on the wall, an extra attachment angle is required	-

* At low temperatures the first few cycles may be run with reduced speed to prolong the operator's lifetime. Can be equipped with a heater for a working range down to -30°C.

4.6 Selection guidelines for operation type

Door size m ²	Openings / day			
	1-5 day	5-10 day	10-15 day	>25 day
0 – 10	<input type="checkbox"/> / <input checked="" type="checkbox"/>	<input type="checkbox"/> / <input checked="" type="checkbox"/>	<input checked="" type="checkbox"/> / <input checked="" type="checkbox"/>	<input checked="" type="checkbox"/> / <input checked="" type="checkbox"/>
10 – 20	<input type="checkbox"/> / <input checked="" type="checkbox"/>	<input checked="" type="checkbox"/>	<input checked="" type="checkbox"/> / <input checked="" type="checkbox"/>	<input checked="" type="checkbox"/> / <input checked="" type="checkbox"/>
> 20 - 42	<input checked="" type="checkbox"/>	<input checked="" type="checkbox"/>	<input checked="" type="checkbox"/> / <input checked="" type="checkbox"/>	<input checked="" type="checkbox"/> / <input checked="" type="checkbox"/>
> 42*	<input checked="" type="checkbox"/>	<input checked="" type="checkbox"/>	<input checked="" type="checkbox"/> / <input checked="" type="checkbox"/>	<input checked="" type="checkbox"/> / <input checked="" type="checkbox"/>

- Manual operation
- Electrical operation
- Automated operation

4.7 Selection guidelines for door operator

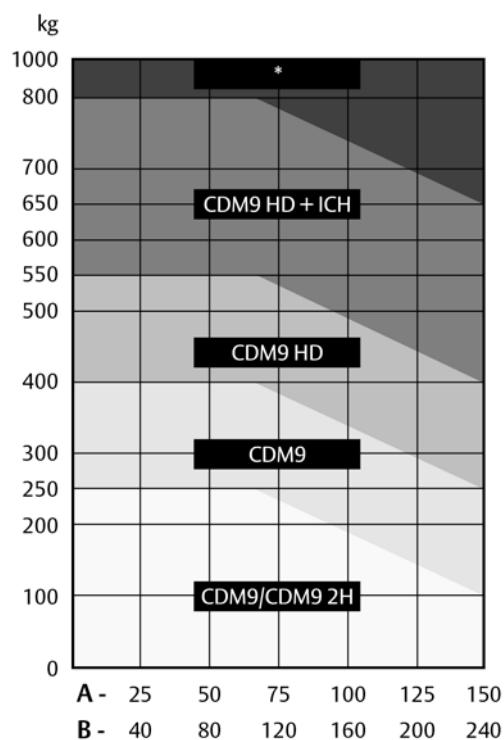

* Custom support Landskrona

Door openings/day

A. Over 300 days/year

B. Over 220 days/year

Average door weight

Steel door : 13 kg/m²

Alu door : 10 kg/m²

4.8 950 Door control system

The 950 Door control system is the most advanced control unit that is prepared for one or more physical upgrades from the entire range of automation systems. An automation system allows door operation by sensors or remote control.

This control unit contains a 3-digit diagnostics display that allows efficient troubleshooting and displays the number of door cycles. Together with the service indicator, this extra feature allows advanced maintenance planning to users where the door is an essential element of internal logistics.



- Dimensions: 300 x 400 x 165 mm (wxhxd)

4.9 Guidelines for automation

The “Automation D-kits” are packages of common combinations. These kits can also be supplemented by “additions to D-kits”.

Automation D-kits	D1	D2	D3	D4	D5	D6
Interlocking	<input checked="" type="checkbox"/>	<input checked="" type="checkbox"/>	<input checked="" type="checkbox"/>	<input checked="" type="checkbox"/>	<input checked="" type="checkbox"/>	<input checked="" type="checkbox"/>
Magnetic loop		<input checked="" type="checkbox"/>		<input checked="" type="checkbox"/>		<input checked="" type="checkbox"/>
Traffic lights - Green + Red					<input checked="" type="checkbox"/>	<input checked="" type="checkbox"/>
Warning lights - Red	<input checked="" type="checkbox"/>			<input checked="" type="checkbox"/>		
Additions to D-kits						
Warning lights – Green	<input type="checkbox"/>	<input type="checkbox"/>	<input type="checkbox"/>	<input type="checkbox"/>		
Traffic lights - Green + Red	<input type="checkbox"/>	<input type="checkbox"/>	<input type="checkbox"/>	<input type="checkbox"/>		
Relay box	<input type="checkbox"/>	<input type="checkbox"/>	<input type="checkbox"/>	<input type="checkbox"/>	<input type="checkbox"/>	<input type="checkbox"/>
Radar	<input type="checkbox"/>	<input type="checkbox"/>	<input type="checkbox"/>	<input type="checkbox"/>	<input type="checkbox"/>	<input type="checkbox"/>

- Standard Option / Available

4.10 Access and automation

ASSA ABLOY offers a wide range of functions that allows advanced opening and safety control. Please refer to the specification sheet of the control units to see which functions apply to which models.

4.10.1 Basic control functions

4.10.1.1 Interlocking

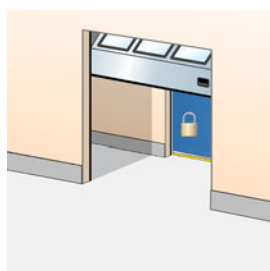

Developed for climate control or safety; If door A is open, door B cannot be opened. If door B is open, door A cannot be opened. An interlocked door can remember an up-command, if selected via a micro switch.

4.10.1.2 Reduced opening

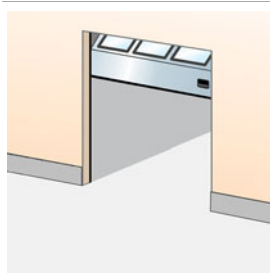

When it is unnecessary or undesirable to fully open a door, an additional switch can be used to open the door to a pre-programmed reduced opening position.

4.10.2 External control functions

4.10.2.1 External push button box

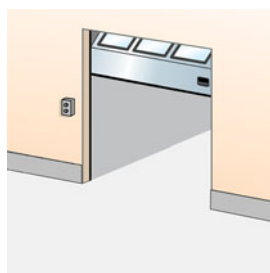

An extra control box is installed outside the building or inside close to the door if the main control unit needs to be installed away from the door opening. Installed on the inside or outside wall beside the door.

4.10.2.2 Pull-rope switch

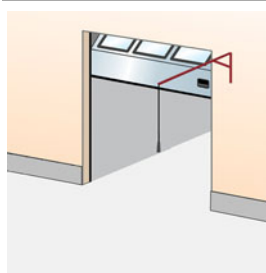

A pull-rope switch above the door opening can be operated from e.g. a forklift truck. Pulling the rope opens a closed door or closes an opened door. Installed on the inside construction above the door.

4.10.2.3 Remote control

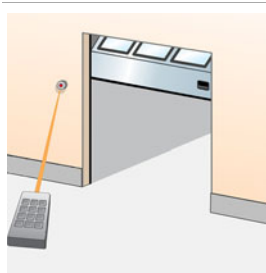

A hand-held radio transmitter allows door operation from a vehicle or any position within 50-100 meters from the receiver and aerial at the door. For closing, the door can be provided with a photocell beam. Receiver installed in control unit, antenna installed on the wall beside the door.

4.10.3 Automatic control functions

4.10.3.1 Magnetic loop

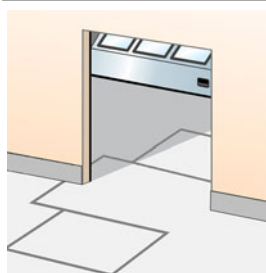

A sensor in the floor detects a metal object (usually forklift trucks, pallet trucks) and opens the door automatically. This is an ideal solution for frequent vehicle traffic. Installed on the outside, inside or both sides of the door in the floor.

4.10.3.2 Radar

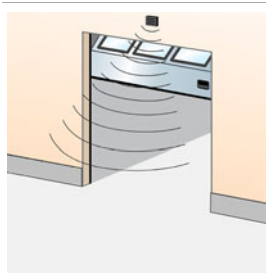

An infrared sensor above the door detects an object (person, vehicle) within a specified distance from the door and opens the door automatically. This is an ideal solution for frequent vehicle or personal traffic. Often combined with automatic closing. Installed on the inside or outside wall above the door.

4.10.3.3 Photocell open door

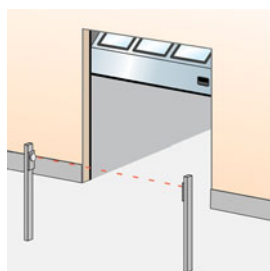

A set of photocells on pillars, on each side of the door. When a person or vehicle passes between the photocells, the beam is interrupted and the door opens. Photocells installed on pillars, away from the door.

4.10.4.3 Safety photocells 2-channel

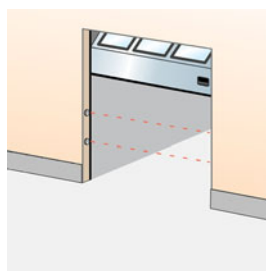

Two sets of photocell transmitter and receiver are installed in the door opening. If one or both photocell beams are interrupted during closing, the door will stop in less than 30mm and reverse to the fully open position. Installed in the door opening.

4.10.3.4 Automatic closing

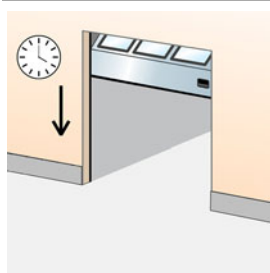

A programmable timer that closes the door after a specified time, counted from either the fully open position and/or from passing through the photocell beam. Adjustable micro switches in control unit.

4.10.4.4 Warning lights - Red

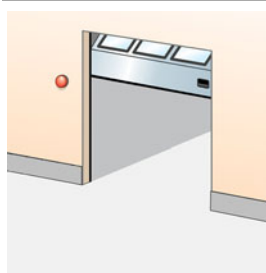

Two red warning lights giving information on the current door behaviour. Flashing light before or during door movement. Optional: Continuous light before and during door movement. Installed on the inside and outside wall beside the door.

4.10.4 Safety functions

4.10.4.1 Safety edge

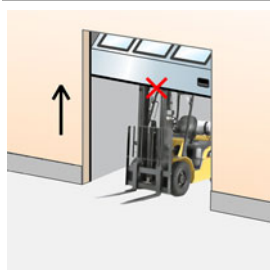

As a standard, all doors that have the impulse-close function or any form of automated closing, are equipped with a safety edge. The pneumatic sensor in the bottom seal detects any obstruction under a closing door and reverses the door. Installed in the bottom seal.

4.10.4.5 Warning lights - Green

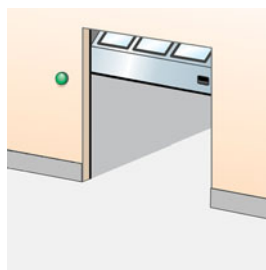

One or two green warning lights indicating the open position of the door by continuous light signal. Installed on the inside and/or outside wall beside the door.

4.10.4.2 Safety photocells 1-channel

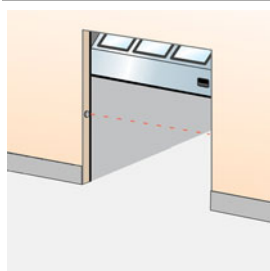

A set of a photocell transmitter and receiver is installed in the door opening. If the photocell beam is interrupted during closing, the door will stop in less than 30mm and reverse to the fully open position. Installed in the door opening.

4.10.4.6 Traffic lights - Red & Green

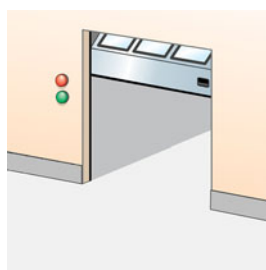

If traffic through a door needs to be directed; two red and two green traffic lights can be installed to indicate traffic direction. From the side where a vehicle is first detected to approach the door, the green traffic light comes on. The opposing side shows a red traffic light. Traffic from this direction must give way to the other. Usually installed in e.g. parking garages. Installed on the inside and outside wall beside the door.

4.10.5 Additional functions

4.10.5.1 UPS battery backup



When mains failure cannot be permitted or an increased risk of mains failure is predicted, the UPS battery backup system can be installed to store enough energy for 5 door cycles. Installed on the inside wall beside the door.

4.10.5.2 Relay box



A sealed connection box makes it possible to safely connect external high-voltage equipment.

5. Building and space requirements

5.1 Building preparations

5.1.1 Installation preparations

The ASSA ABLOY OH1042P overhead sectional door is shipped in parts and installed on-site. All necessary installation material is included. For every track type ASSA ABLOY offers specific installation kits to position the door in the building facade.

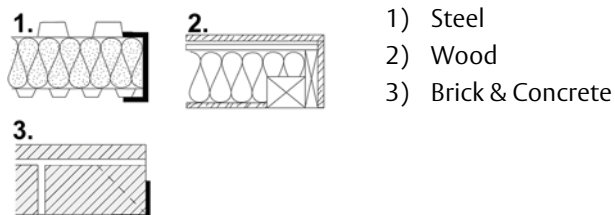

5.1.2 Deflection of door panels

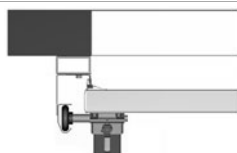

We would advise the following doors to be installed on a frame, equipped with an A-65 top seal.

- Doors DLW > 6050 mm
- Doors DLW ≥ 4050 mm with a dark outside colour, frequently exposed to solar heat.

5.2 Space requirements

DLH	= Daylight Height	The height of the clear opening
DLW	= Daylight Width	The width of the clear opening
D	= Depth	The space between the inner side of the wall and the end of the horizontal track construction
h	= Excess height	The extra space required above the daylight height.
SL	= Side space Left	The space required for tracks beside the daylight width.
SR	= Side space Right	The space required for tracks beside the daylight width.

The grey marked area in the illustrations shows the free space required by door movement. Extra space requirements for electrically operated doors are stated in the operator specifications. Extra space requirements for passdoors are stated in the passdoor specifications.

5.2.1 Space requirements SL

h	485 mm (DLH ≤ 4500 mm) 510 mm (DLH > 4500 mm) 575 mm (with center operator)
SL/SR	132 mm Manual, 212 mm Hoist-D/T, 278 mm Hoist-U, 270 mm Operator, 310 mm Operator+Hoist (with outer support bearing + 45 mm)
D	DLH + 600 mm
For details see the specific building preparation drawings	

Side and top view

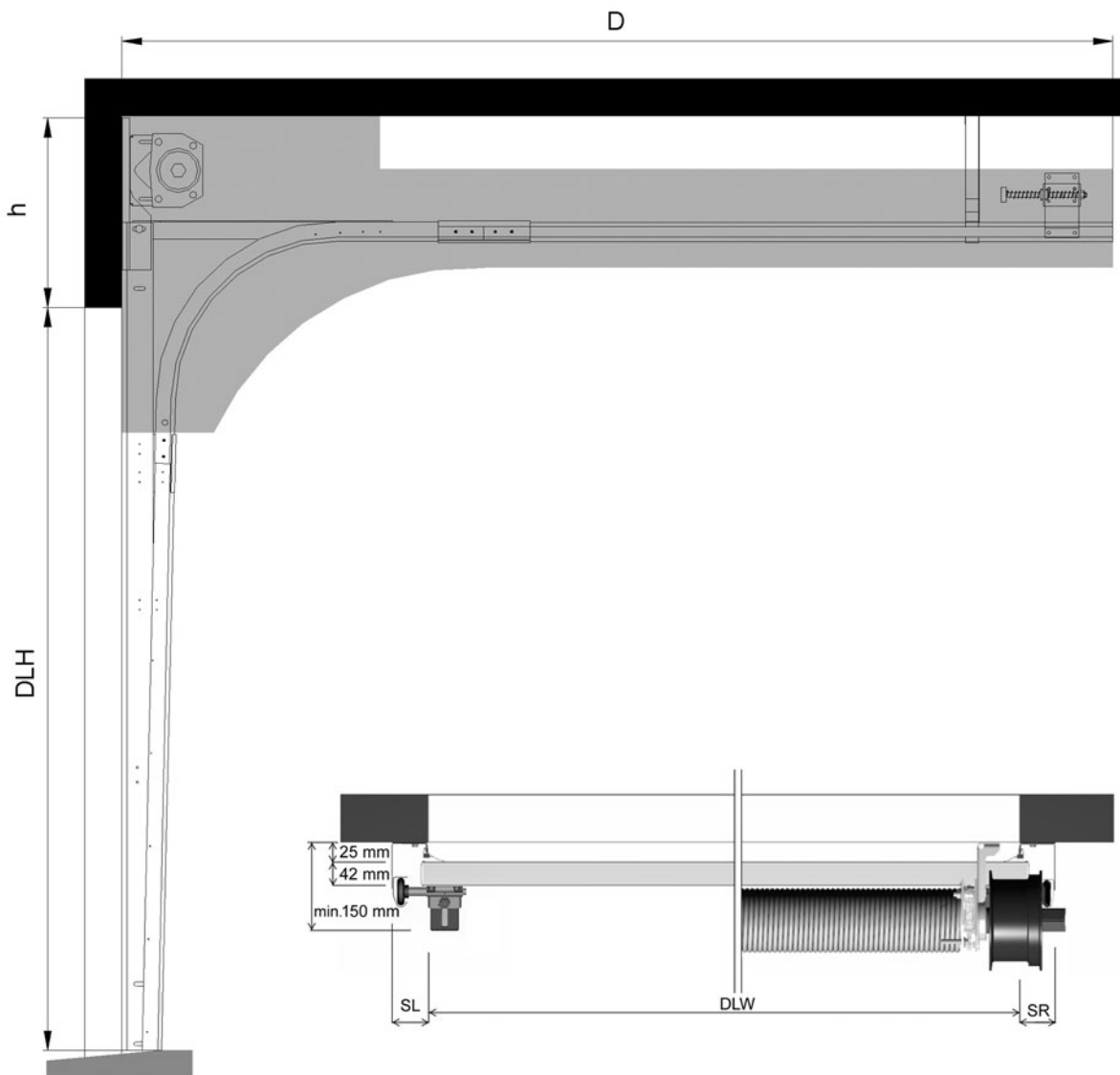

5.2.2 Space requirements SLL

h	400 mm 475 mm (with center operator)
SL/SR	132 mm Manual, 212 mm Hoist-D/T, 278 mm Hoist-U, 270 mm Operator, 310 mm Operator+Hoist (with outer support bearing + 45 mm)
D	DLH + 900 mm
DLW / DLH	≤ 5500 mm / ≤ 4250 mm
For details see the specific building preparation drawings	

Side and top view

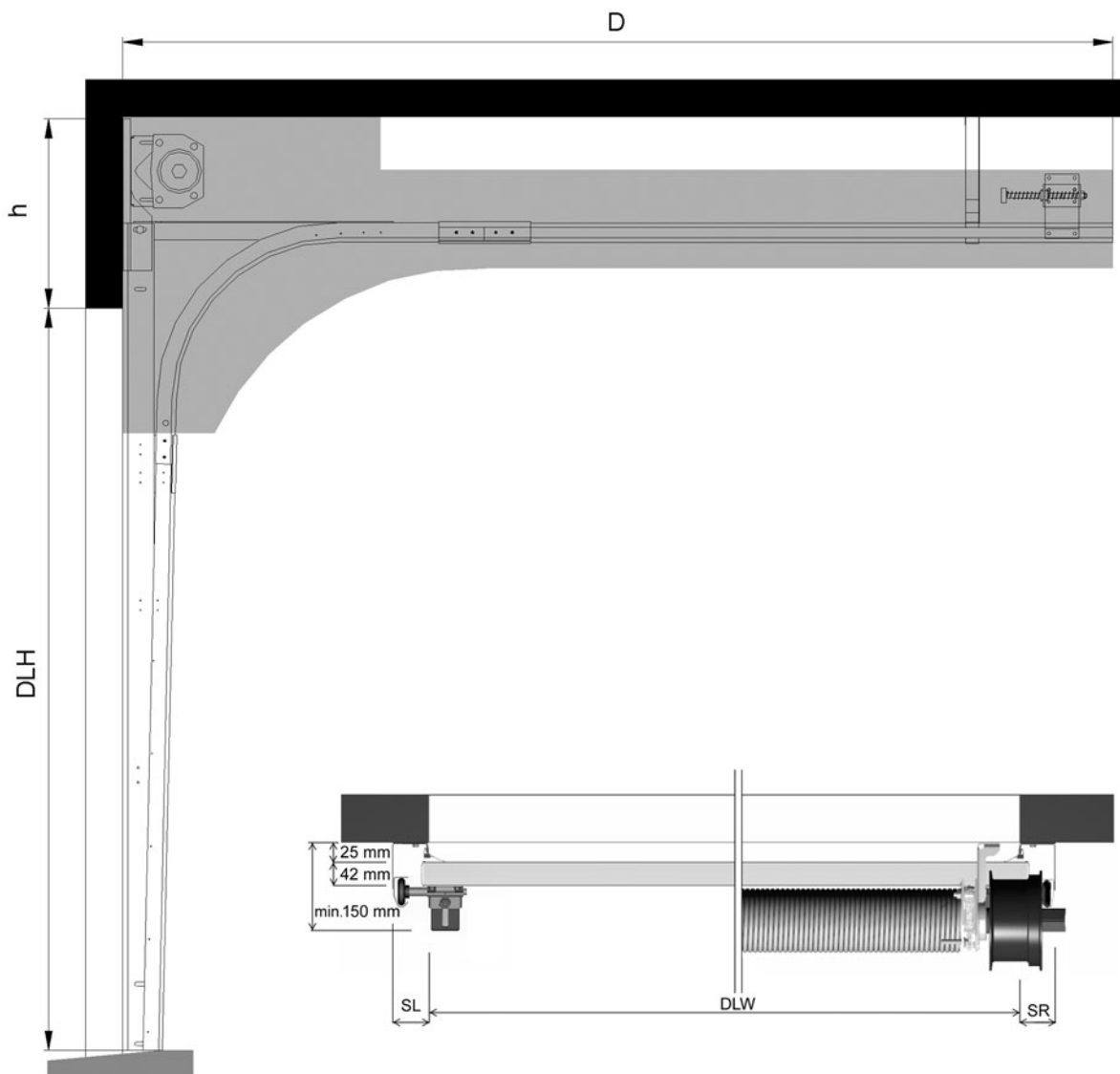

5.2.3 Space requirements HL

	HL	HL with Beam
h	HL+320 mm (HL ≤ 3321 mm) HL+370 mm (HL > 3321 mm) HL+400 mm (with center operator)	HL+220 mm
SL/SR	132 mm Manual, 212 mm Hoist-D/T, 278 mm Hoist-U, 270 mm Operator, 310 mm Operator+Hoist (with outer support bearing + 45 mm)	106 mm Manual, 212 mm Hoist-D/T, 278 mm Hoist-U, 312 mm Operator, 352 mm Operator+Hoist (with outer support bearing + 64 mm)
D	DLH - HL + 950 mm	DLH - HL + 950 mm

For details see the specific building preparation drawings

We would advise the following doors to be installed on a frame, equipped with an A-65 top seal.

- Doors DLW > 6050 mm
- Doors DLW ≥ 4050 mm with a dark outside colour, frequently exposed to solar heat.

Side and top view

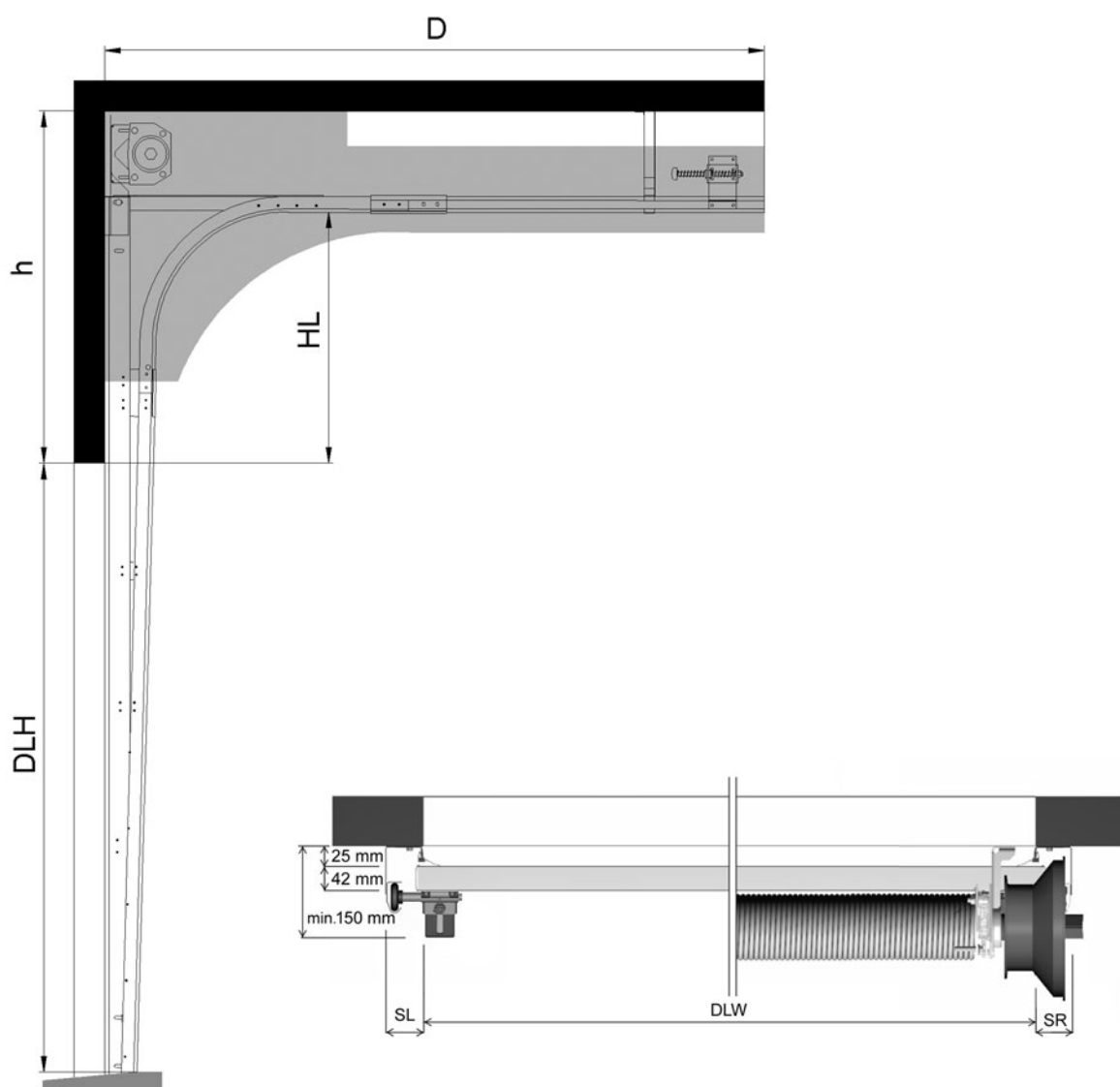

5.2.4 Space requirements HHL

h	HL+260 mm (HL ≤ 3321 mm), HL+285 mm (HL > 3321 mm)
SL/SR	132 mm Manual, 228 mm Hoist-D/T, 278 mm Hoist-U, 304 mm Operator, 344 mm Operator+Hoist (with outer support bearing + 45 mm)
D	DLH - HL + 1100 mm

For details see the specific building preparation drawings
We would advise the following doors to be installed on a frame, equipped with an A-65 top seal.

- Doors DLW > 6050 mm
- Doors DLW ≥ 4050 mm with a dark outside colour, frequently exposed to solar heat.

Side and top view

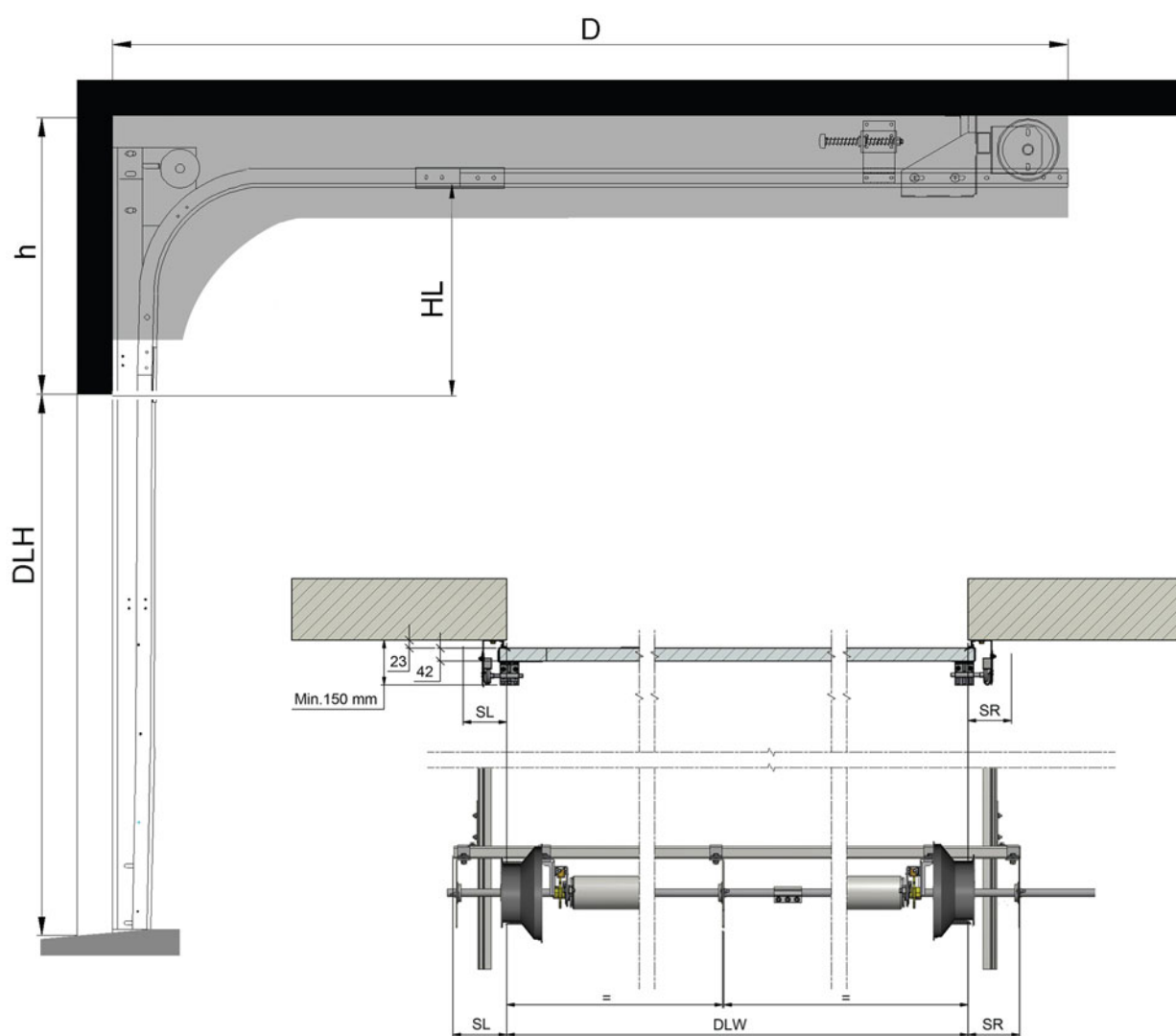

5.2.5 Space requirements LL

h	265 mm (≤ 250 kg without passdoor) 300 mm (> 250 kg or passdoor)
SL/SR	132 mm Manual, 228 mm Hoist-D/T, 278 mm Hoist-U, 304 mm Operator, 344 mm Operator+Hoist (with outer support bearing + 45 mm)
D	DLH + 1250 mm
	For details see the specific building preparation drawings *** With low threshold passdoor only

Side and top view

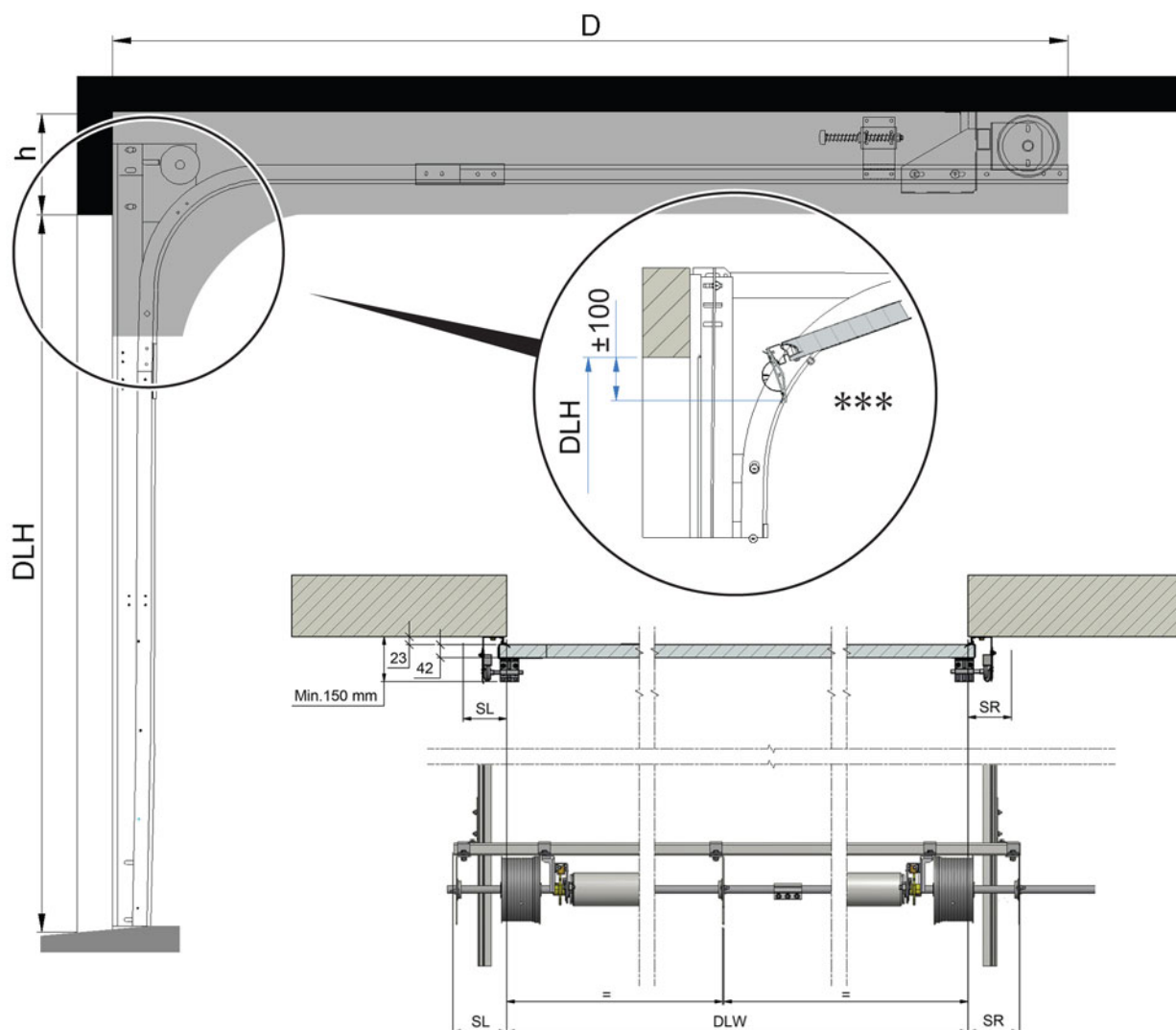

5.2.6 Space requirements VL

h	DLH + 365 mm
SL/SR	110 mm Manual, 216 mm Hoist-D/T, 278 mm Hoist-U, 312 mm Operator, 352 mm Operator+Hoist (with outer support bearing + 64 mm)
D	VLA = 450 mm VLT = 525 mm (manual) VLT = 610 mm (operator)

For details see the specific building preparation drawings

- VL doors: $DLW \leq 3000$ mm and $DLH \leq 3350$ = VLA = no beam installed
- VL doors: $DLW > 3000$ mm or $DLH > 3350$ = VLT = installed with beam to support the balancing system
We would advise the following doors to be installed on a frame, equipped with an A-65 top seal.
- Doors $DLW > 6050$ mm
- Doors $DLW \geq 4050$ mm with a dark outside colour, frequently exposed to solar heat.

Side and top view

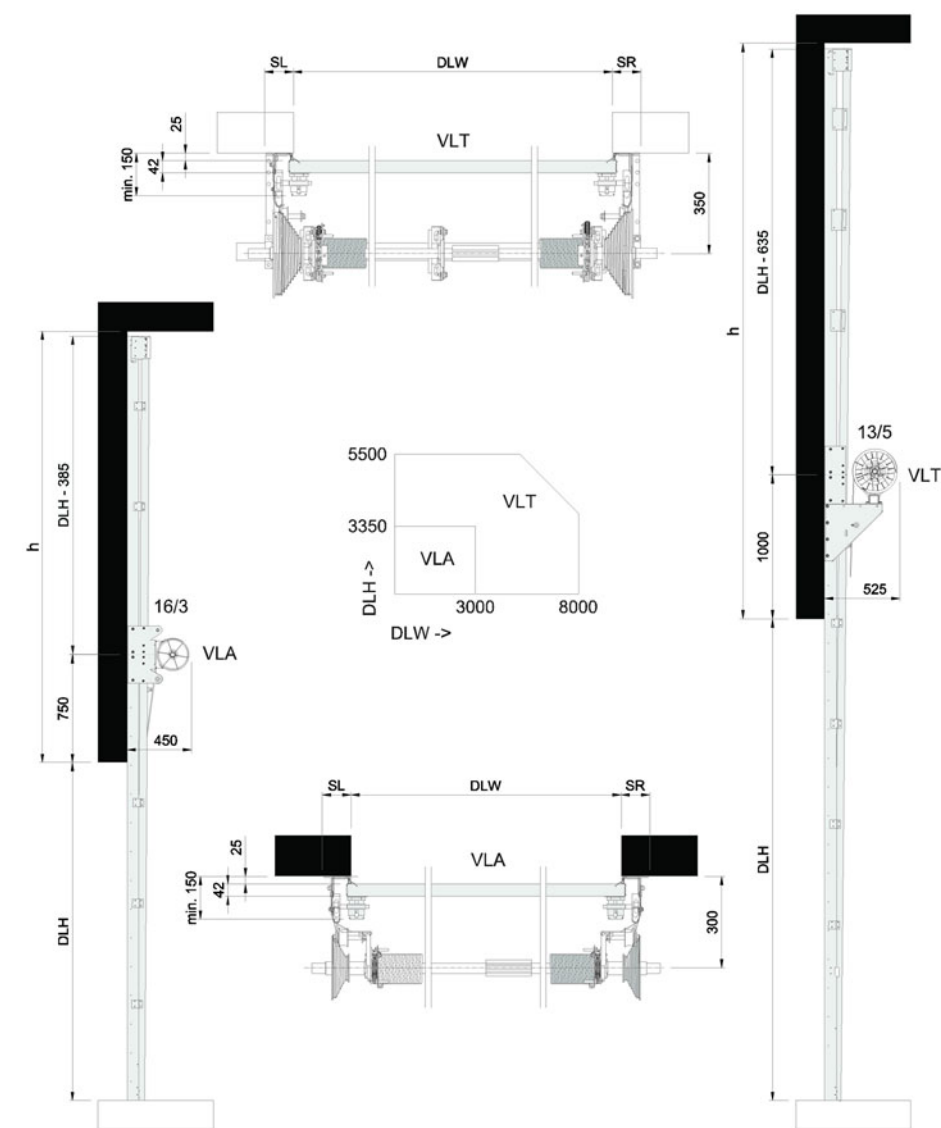

6. Service you can rely on



Gold

The ultimate protection

With full coverage, Gold Service enables you to plan and budget your expenses annually.

- Spare parts for emergency calls
- Labor and travel costs for emergency calls
- Replacement of components according to preventive maintenance schedule and to fulfill legislative and safety requirements

Silver

Added advantages

With cover for all service calls during business hours, Silver Service offers you peace of mind.

- Labor and travel costs for emergency calls
- Preventive maintenance

Bronze

Scheduled Service

With scheduled on site visits, Bronze Service means you know that your doors and docking systems will be regularly serviced and inspected.

- Preventive maintenance

Included in all packages

1-4 scheduled maintenance visits per year	24/7 priority service hotline and fast response	Safety, compliance and quality control checks	Documentation reports provided on site
---	---	---	--

Expert service you can rely on

A healthy business enjoys a steady flow of goods, services and people through its entrances every day. But heavy traffic puts entrances under pressure as every component works to keep them running.

ASSA ABLOY Entrance Systems offer the industry's most complete, flexible service solutions. Because even something as robust and well-engineered as an ASSA ABLOY door or docking system needs to be serviced to stay in great working order.

Pro-active care packages

An ASSA ABLOY service agreement gives you service you can rely on. We have specialized local service technicians on call to take care of your service needs. Equipped with a wide range of spare parts and expertise, to keep your industrial doors and docking systems running.

With an ASSA ABLOY service agreement you can ensure reliable, safe and sustainable operations at every entrance under your agreement, including doors and docking systems, independent of brand.

ASSA ABLOY e-maintenance™ (optional add-on)

For an online overview of your entrance systems and history, add ASSA ABLOY e-maintenance™ to your service package for:

- Easy access to real-time data on all your doors
- Planning, order and service information
- Overview that helps you control lifecycle costs

Index

Numerics

950 Door control system 26

A

Access and automation 27

Acoustic insulation 13

Additional functions 29

Air permeability 12

ALBS 19

ALRB 19

Anti corrosive hardware 21

Automatic closing 28

Automatic control functions 27

Available Options 16

B

Balancing system 11

Basic control functions 27

Bottom seal 10

Building and space requirements ... 30

Building preparations 30

C

Cable break device (CBD) 11

CDM9 Operator 25

CDM9 Operator - 950 Door control
systems 25

CEN Performance 12

Chain hoist 24

Colors 9

Construction 7

Copyright and Disclaimer Notice 2

Cylinder lock 20

D

DAOP 19

DARP 19

Daylight width and daylight height ... 7

Deflection of door panels 30

Description 7

Dimensions 7

Door leaf 7

E

Electrical operation 24

External control functions 27

External push button box 27

F

Features 3

Fixed sections 18

Fixed sections options 18

Frame section 20

G

General 7, 14

Guidelines for automation 26

H

Handle 10

HHL - High lift with spring package at
the end of the horizontal track 15

HL - High Lift 14

I

Installation preparations 30

Interlocking 27

L

Lifetime expectation 12

LL - Low Lift 14

Lock bolt 10

Locks 20

M

Magnetic loop 27

Material 8

N

Number of windows 22

O

Operating forces and safe openings 13

Operating system 24

Optional colors* 20

P

Passdoor Low Threshold 23

Passdoor standard threshold (180mm)
23

Passdoor with low threshold 16

Passdoor with standard threshold (180
mm) 17

Performance 3

Photocell open door 28

Pre-coated colors 9

Protective grating 20

Pull-down rope 24

Pull-rope switch 27

R

Radar 27

Reduced opening 27

Relay box 29

Remote control 27

Resistance to water penetration 12

Resistance to windload 12

S

Safety devices	11
Safety edge	28
Safety functions	28
Safety photocells 1-channel	28
Safety photocells 2-channel	28
Seals	9
Section sizes	7
Selection guidelines for door operator 26	
Selection guidelines for operation type 26	
Service you can rely on	37
Side seal	9
SL - Standard Lift	14
SLL - Standard Lift Low	14
Space requirements	30
Space requirements HHL	34
Space requirements HL	33
Space requirements LL	35
Space requirements SL	31
Space requirements SLL	32
Space requirements VL	36
Special track sets	15
Specifications	22
Spring break device (SBD)	11

T

TARP	19
Technical facts	3
Thermal transmittance	13
Top seal	9
Track sets	14
Traffic lights - Red & Green	28
Types of operation	24

U

UPS battery backup	29
--------------------------	----

V

Vertical cross-section	8
VL - Vertical Lift	15

W

Warning lights - Green	28
Warning lights - Red	28
Wind reinforcement truss	10
Windows	19, 22
Windows and passdoor	22

The ASSA ABLOY Group is the global leader in access solutions.
Every day, we help billions of people to experience a more open world.

ASSA ABLOY
Entrance Systems

ASSA ABLOY Entrance Systems provides solutions for efficient and safe flow of goods and people. Our offering includes a wide range of automated pedestrian, industrial and residential doors, loading dock equipment, perimeter fencing and service.