

High speed door

ASSA ABLOY HS9010PX3, HS8010PX3, HS8020PX3

ASSA ABLOY
Entrance Systems

Experience a safer
and more open world



Medium sized heavy duty high speed door for inside & outside use

The main features of the ASSA ABLOY HS9010PX3, HS8010PX3, HS8020PX3 are:

- For ATEX environment category 3
- Medium-sized, max. 5500 x 5500 mm
- Heavy-duty operations
- Inside and Outside usage
- stainless steel construction incl. bearings and drive
- Unique direct door drive system
- Opening speed up to 1,0 m/s

The fast opening and closing speed improves your traffic flow, provides employee comfort, and saves energy. The unique dual barrel power drive system eliminates the need for weighted bottom bars or tension systems by actively driving the door curtain. An exceptional reliability and smooth operation is ensured by a frequency converter driven motor for a soft start and stop.

The reliable and versatile control unit ensures precise door set up and diagnostics and is enclosed in a robust steel control box. A customer friendly clear display gives a wide range of information like an easy to read cycle counter.

Break-away and Automatic Reset system

ASSA ABLOY high speed doors are equipped with a break-away and automatic reset system. The curtain reintroduces itself after a crash to reduce downtime and maintenance.

Completely safe

Two features make our doors completely safe:

- The soft bottom profile has no rigid parts, it gives way should an obstruction be in the line of closing.
- If the door is hit, the fabric curtain absorbs the impact and releases itself from the side guides to limit damage to the door and surrounding area.

Conform to directive (2014/34/EU):

- Ex 3 G/D
- Ex h IIC T6 EPL Gb
- Ex h IIIC 85°C EPL Db
- Ex db mc ia e IIC T4 EPL Gc
- Ex tb mc tD IIIB 135°C EPL Dc
- CE 0029 APRAGAZ 16ATEX 0150X/1 
- T ambient -10°C ~ +45°C

Technical Data

Min size (W x H)	1000 x 1000 mm
Max size (W x H)	5500 x 5500 mm
Operating speed ¹⁾	opening: up to 1,0 m/s closing: 1,0 m/s
Wind load resistance, EN 12424	HS9010PX3 = class 1 (300 N/m ²) HS8010PX3 = up to class 4 (1000 N/m ²) HS8020PX3 = up to class 5 (>1000 N/m ²)
Water penetration, EN 12425	class 3 (>50 N/m ²)
Air permeability, EN 12426	class 1 for doors up to 3500 x 3500 mm
Thermal transmittance	6,02 W/ (m ² K)
Power Supply	230V - 16A
Curtain Color	Black, Anti static
Opening commands	Atex Push button or Pull switch
Vision	H 350 mm vision strip max. 2 rows
<small>1) Depending on door size</small>	

Dimensional specifications

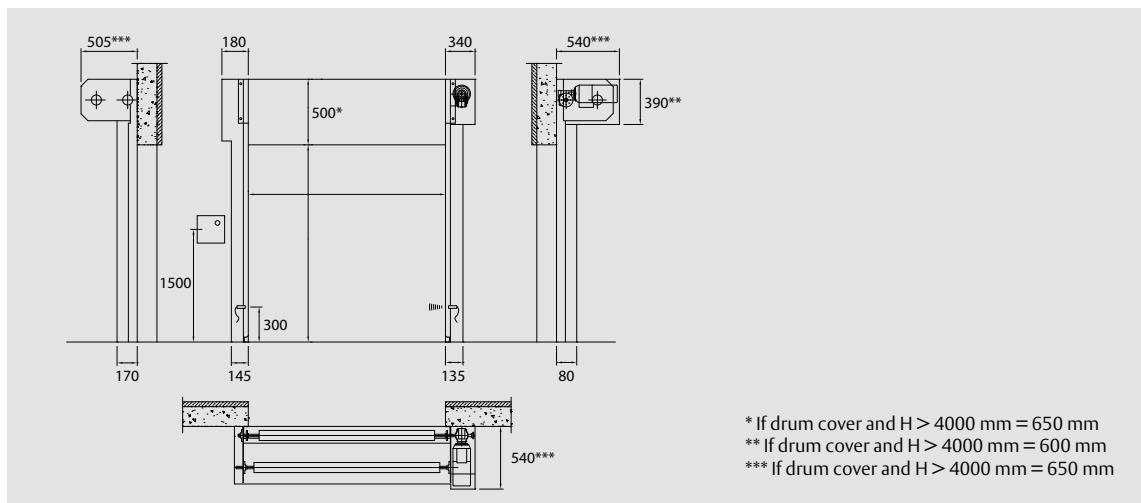

Ex II 3 GD IIC T4 IIIB 135°C

Product	Category 1	Category 2	Category 3
User zone	Zone 0/20	Zone 1/21	Zone 2/22
Zone criteria	Where an explosive atmosphere is continuously present for long periods of time. (>1000 h./year) Still safe with two faults.	Where an explosive atmosphere is likely to occur in normal operation. (Between 10>1000 h./year) Increased safety under abnormal operating conditions.	Where an explosive atmosphere is not likely to occur in normal operation and if it does occur it will exist only for a short period of time (>10 h./year) Equipment which is appropriate under normal conditions.
Hazard	Certain	Likely	Not likely
Approved categories	1G 1D	1G/2G 1D/2D	1G/2G/3G 1D/2D/3D

Ex II 3 GD IIC T4 IIIB 135°C

Explosion groups	Temperature class					
	T1	T2	T3	T4	T5	T6
Min. ignition temperature or max. surface temperature	450 °C	300 °C	200 °C	135 °C	100 °C	85 °C
I (Mining)	Methane					
IIA	Acetone Ammonia Benzene Acetic acid Ethane Ethyl acetate Methanol Naphthalene Phenol Propane	i-Amylacetate n-Butane n-Butane alcohol	Benzines Diesel fuels Fuel oils n-Hexane	Acetaldehyde		
IIIB	Town gas	Ethylene Ethylene oxide	Hydrogen sulphide	Ethyl ether		
IIC	Hydrogen					Carbon disulphide

Ex II 3 GD IIC T4 IIIB 135°C

Dust sub groups	Dust type
I	Coal Dust
IIIA	Flyings
IIIB	Non-conductive
IIC	Conductive