

Product datasheet

Dock leveler

ASSA ABLOY DL6130C

ASSA ABLOY
Entrance Systems

Experience a safer
and more open world



Copyright and Disclaimer Notice

Although the contents of this publication have been compiled with the greatest possible care, ASSA ABLOY Entrance Systems cannot accept liability for any damage that might arise from errors or omissions in this publication. We also reserve the right to make appropriate technical modifications/replacements without prior notice.

No rights can be derived from the contents of this document.

Color guides: Color differences may occur due to different printing and publication methods.

No part of this publication may be copied or published by means of scanning, printing, photocopying, microfilm or any other process whatsoever without prior permission in writing by ASSA ABLOY Entrance Systems.

Copyright © ASSA ABLOY Entrance Systems AB 2006-2022.

All rights reserved.

ASSA ABLOY, Besam, Crawford, Albany and Megadoor as words and logo are trademarks belonging to the ASSA ABLOY Group.

Technical facts

Features

Sizes - leveler height	800, 900 mm		
Sizes - nominal length*	3000, 3500, 4000, 4500 mm		
Sizes - nominal width	2000, 2200 mm		
Sizes - lip extension (LE)	500, 1000 mm		
Vertical working range	Above dock (LE 500 mm): Below dock (LE 500 mm):	0 - 560 mm 0 - 650 mm	Above dock (LE 1000 mm): 0 - 620 mm Below dock (LE 1000 mm): 0 - 700 mm
Platform tear plate	8 mm (8/10)		
Surface treatment	Standard: Option:	RAL 5010 RAL 3002 RAL 6005 RAL 9005 Hot dip galvanised	
Control unit	Leveler control Door control Shelter control Fault & service indicator		

* Other sizes are available on request

Performance

Load capacity	6 tonnes (60kN) / 2 tonnes (20kN)		
Max. point load	6,5 N / mm ² (8 mm tear plate)		
Motor hydraulic unit	1,5kW		
Mains supply	400V 3-phase, 230V 3-phase		
Control unit protection class	950-series IP54		
Allowable oil types	ASSA ABLOY standard hydraulic oil (-20°C - +60°C) ASSA ABLOY low temperature hydraulic oil (-30°C - +60°C) ASSA ABLOY bio hydraulic oil (-20°C - +60°C)		
Magnetic valves	24V/DC 18W S1		
Surface treatment paint class 1	80µm Corrosive Category C2 M acc. DIN EN ISO 12944-2		
Surface treatment paint class 3	160µm Corrosive Category C3 M acc. DIN EN ISO 12944-2		
Surface treatment galvanised	Hot dip galvanised 80µm Corrosive category C4 & C5-I M acc. DIN EN ISO 12944-2		

Contents

Copyright and Disclaimer Notice	2
Technical facts	3
Contents	4
1. Description	6
1.1 General	6
1.1.1 Application	6
1.1.2 Mode of operation	6
1.1.3 Overview	6
1.1.4 Standard	6
1.1.5 Options	6
1.2 Mini-combidock lip	7
1.2.1 Big truck	7
1.2.2 City van	7
1.2.3 Function telescopic lip in city van mode	8
1.3 Platform	8
1.3.1 Platform tear-plate thickness	8
1.3.2 EPDM seal	8
1.3.3 Slip protection / noise reduction	8
1.4 Surface	9
1.4.1 Painting	9
1.4.2 Hot galvanising	9
1.5 Frames - connection to building	10
1.5.1 T - leveler frame for embedding in concrete	10
1.5.2 T - 200 leveler frame for embedding in concrete	10
1.5.3 W - leveler frame for welding	10
1.6 Docking control systems	11
1.6.1 950 Docking LA CD	11
1.6.2 950 Docking LA CD	11
1.6.3 950 Docking DLA CD	11
1.6.4 950 Docking LSA CD	11
1.6.5 950 Docking DLSA CD	11
1.6.6 950 Docking power cable	11
1.7 Equipment	12
1.7.1 Buffers	12
1.7.2 ASSA ABLOY DE6190WC Wheel chock	13
1.7.3 ASSA ABLOY DE6090TLS Traffic light system	13
1.7.4 ASSA ABLOY DE6090DL Dock light Heavy Duty LED	13
1.7.5 ASSA ABLOY DE6090FL Fan light	13
1.7.6 Parking guides	13

2.	Selection guide	14
2.1	Load capacity according to EN 1398 14	
2.1.1	Rated load	14
2.1.2	Axle load	14
2.1.3	Dynamic load	14
2.2	Select the load capacity	14
2.2.1	Example for lorries	14
2.2.2	Example for vans	14
2.3	Select the leveler length	14
2.3.1	The calculation	14
2.3.2	Example	14
2.4	Nominal width.....	15
3.	Specifications	16
3.1	Dimensions.....	16
3.1.1	Working range below dock B* – inside LH.....	17
3.1.2	Working range below dock B – down to LP.....	17
3.2	Platform thickness.....	18
3.3	Control unit	18
3.3.1	Dimensions	18
3.3.2	Functions	18
4.	CEN Performance	19
4.1	Safety according to the European Standard EN 1398	19
5.	Building and space requirements	20
5.1	Electrical preparations.....	20
5.2	Pit preparations.....	21
5.2.1	T - frame (T standard and T200).....	21
5.2.2	W - frame	21
6.	Service you can rely on	22
	Index	23

1. Description

1.1 General

1.1.1 Application

The ASSA ABLOY DL6130C combidock is the optimal solution for docking bays where vehicles of various sizes are loading and unloading. For smaller vehicles only the 1000 mm wide middle section of the lip is extended. For loading and unloading large vehicles, the full 2000 mm wide lip can be extended.

The ASSA ABLOY DL6130C combidock system meets the standard demands of most loading operations and fully complies with rules and regulations of the European Standard EN 1398.

1.1.2 Mode of operation

The operation of the ASSA ABLOY DL6130C combidock is based on an electro-hydraulic telescopic lip, controlled by a semi-automatic control unit.

When the dock leveler is raised, the lip extends and the leveler lowers gently onto the lorry bed. After loading or unloading, the leveler is raised again, the lip retracts and the platform returns to its parking position.

1.1.3 Overview

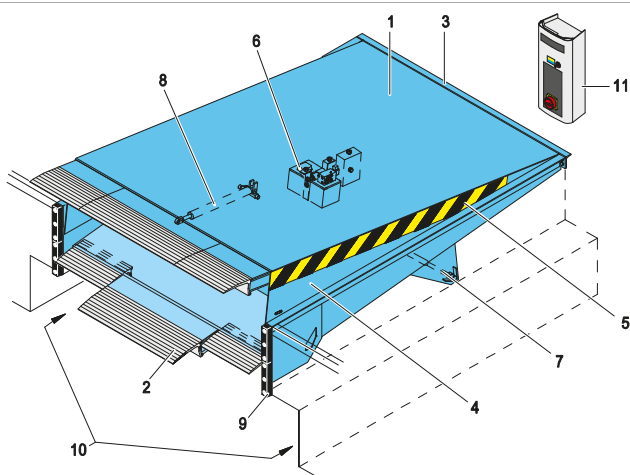

- 1) Leveler platform
- 2) Telescopic lip
- 3) Leveler frame
- 4) Side plates
- 5) Warning stripes
- 6) Hydraulic unit
- 7) Lift cylinders
- 8) Telescopic lip cylinder
- 9) Buffers (optional)
- 10) Tail lift recess
- 11) Control nut

1.1.4 Standard

Frames - connection to building:	T-frame
Surface	Painting RAL 5010 or RAL 9005
Hydraulic Equipment	Low noise hydraulic unit Two hydraulic lift cylinders One hydraulic lip cylinder
Lip	Lip length 500 mm Aluminium lip

1.1.5 Options

Frames - connection to building	T200 - frame W-frame [frame for welding]
Surface	Painting RAL 3002 or RAL 6005 Hot dip galvanised
Hydraulic equipment	Low temperature oil Bio oil
Energy & Ergonomics	EPDM seal Slip protection/noise reduction
Lip option	Lip length 1000 mm*

* The lip length of 1000 mm is suitable for ISO loading bays with the leveler completely behind the door, or for loading bays with a safety zone in front of the dock leveler having a buffer construction of at least 500 mm deep.

1.2 Mini-combidock lip

The telescopic lip of the ASSA ABLOY DL6130C combidock is divided in 3 sections. The middle section is approximately 1000 mm wide for leveler width NW 2000 mm, and 1200 mm for NW 2200 mm, fit various types of vehicles (small vehicles like vans). When the outer sections are included, the lip is approximately 2000 mm wide (or 2200 mm), to fit large vehicles like trucks.

The lip is extremely flat, to secure a smooth transition from platform to vehicle bed.

1.2.1 Big truck

For loading and unloading large vehicles, the selector switch of the control unit is put in the position: Articulated lorries with high loading bearing capacity. In this position the full 2000 mm (or 2200) wide lip is extended during the operation of the lip.

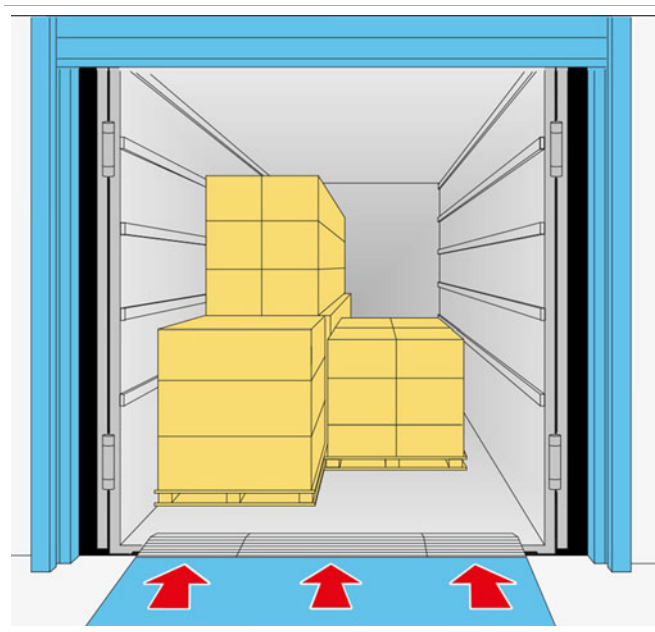

1.2.2 City van

For loading and unloading city vans, the selector switch of the control unit is put in the position: Small vans with low loading bearing capacity. In this position only the 1000 mm (or 1200) wide middle section of the lip is extended during the operation of the lip.

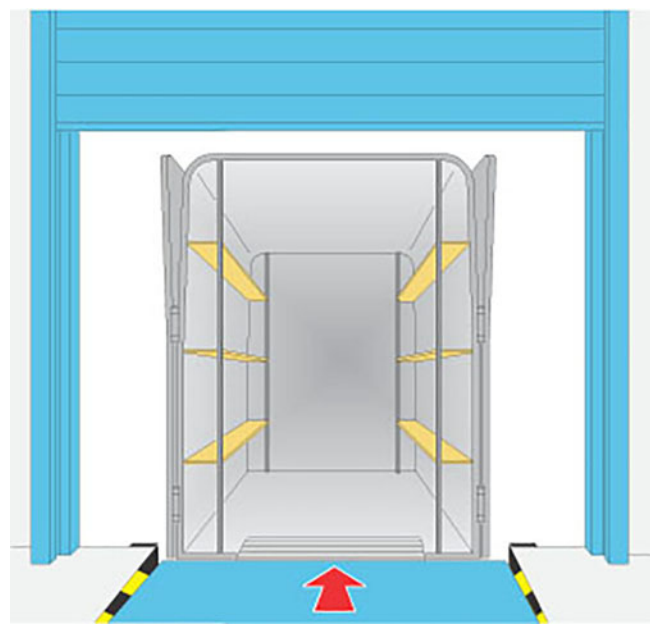

1.2.3 Function telescopic lip in city van mode

Use the hold-to-run button to lift the platform. When the platform has been lifted up 100 mm, the control box releases the activation of the telescopic lip. Use the hold-to-run button to extend the lip. The lip extension has 3 phases.

- 1) All three segments move out 80 mm.

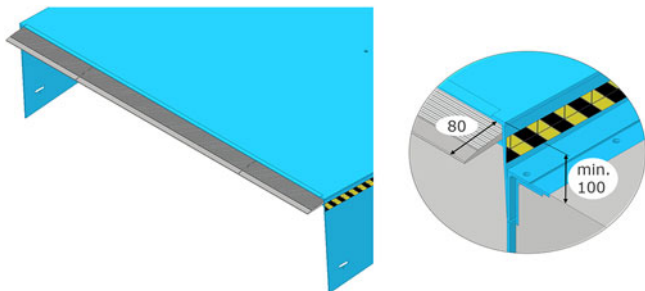

- 2) Only the middle segment moves out to 240 mm.

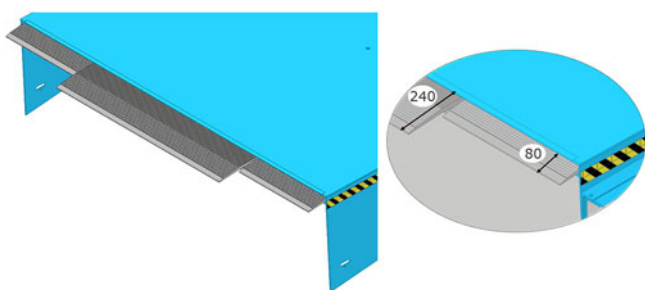

- 3) The lip moves out completely to the maximum length of 500 or 1000 mm, keeping a distance of 160 mm from the middle segment to the side segments.

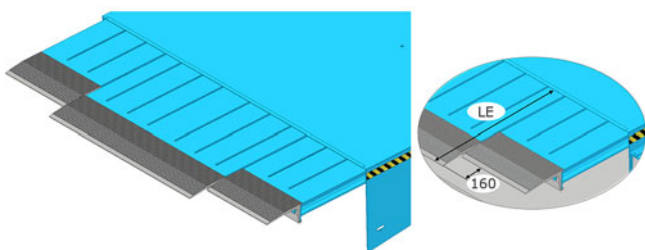

Correct positioning of the lip on the vehicle bed

The lip must be extended at least 240 mm before it functions correctly for the loading operation of the city van. Release the lip extend button when the lip is in the right position to lower onto the vehicle bed with at least 100 mm overlap.

1.3 Platform

1.3.1 Platform tear-plate thickness

The 8 mm (8/10) tear-plate is designed for loading and unloading with typical 4 wheel pneumatic-tired fork-lift trucks, and is also suitable for handling equipment with high point loads, such as electric pallet trucks.

1.3.2 EPDM seal

To seal the gap between leveler and pit, an EPDM seal can be factory-installed between the flexible platform and frame. By reducing draughts into the building, working conditions improve and energy savings increase.



1.3.3 Slip protection / noise reduction

Applying a polyurethane slip protection coating on the lip and platform ensures a durable non-slip and noise reduction surface. The effect is a smooth and comfortable surface for handling equipment that is less receptive to wear and tear.

The PU coating material is resistant to impact, to thermal impact and most types of chemicals and it has a high loading capacity.

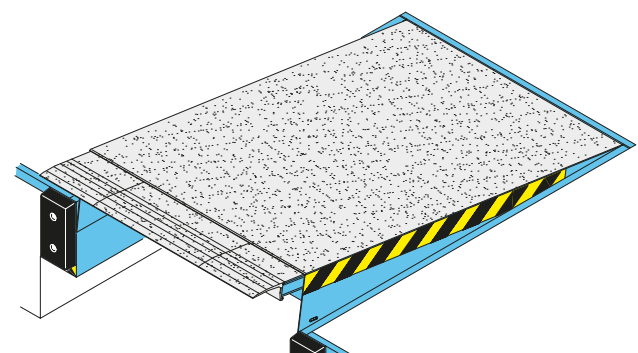

1.4 Surface

1.4.1 Painting

1.4.1.1 Colors

The dock leveler standard finish is painted. The standard colors are:

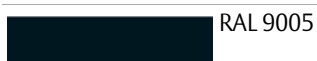

Colors available as option are:



1.4.1.2 Standard paint class

If the dock leveler is to be used in a rural area, the standard finish is:

- Paint class 1; 80 µm factory painted for corrosive category C2 M

1.4.1.3 Paint classes

If the dock leveler is to be used in an urban or industrial atmosphere, or in a coastal area, it may be appropriate to select an alternative paint class with increased resistance to corrosion C3 M.

- Paint class 3; 160 µm factory painted for corrosive category C3 M

1.4.2 Hot galvanising

To increase corrosion protection to C4 for saline coastal areas or C5-I for aggressive or humid atmospheres, the dock leveler can be delivered with hot dip galvanised (80 µm) steel parts.

1.5 Frames - connection to building

The frame is the leveler's connection point to the building and a rigid support for the leveler.

The ASSA ABLOY DL6130C combidock is available with different frame types. The frame can be embedded in concrete or installed via screws or welding. All frames are illustrated with the tail lift recess. The levelers are also available without tail lift recess.

1.5.1 T - leveler frame for embedding in concrete

The T-frame is installed in one step. The leveler is directly embedded in concrete.

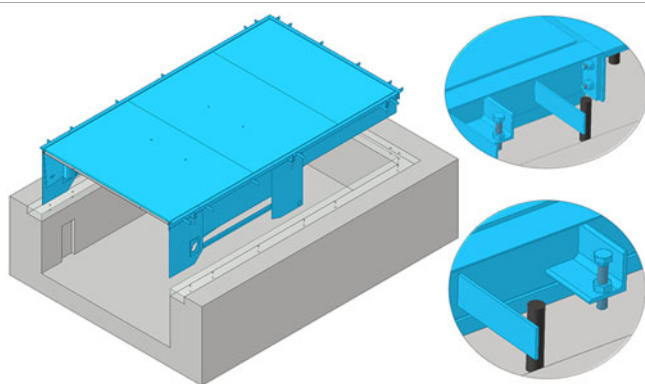

1.5.2 T - 200 leveler frame for embedding in concrete

The rear vertical part of the T-200 frame is prolonged from 100 mm to 200 mm to improve the situation during the process of pouring the concrete to finish floor level in the building, when the dock edge gap of the concrete pit is not fully in line with out pit drawing.

AP represents the adjustment position of the frame, the screws are rotated in order to obtain the flatness of the frame with the floor.

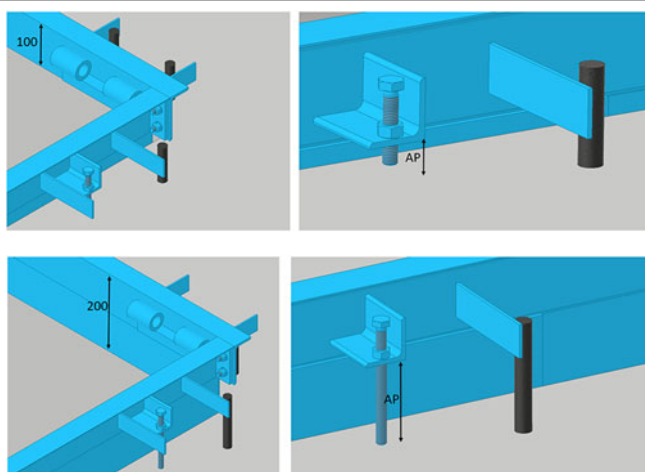

1.5.3 W - leveler frame for welding

The W-frame is designed to weld the leveler directly to the floor slab. In case of future replacement, the welding points can be ground away.

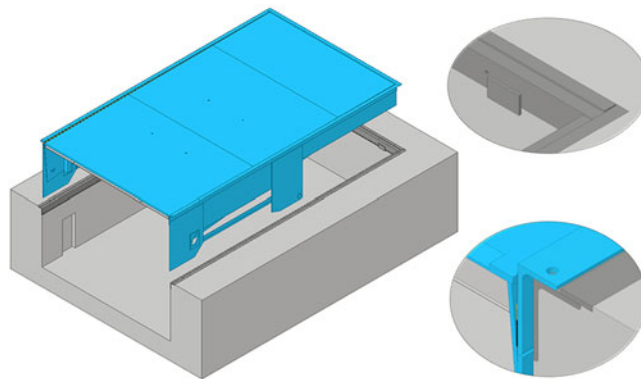

1.6 Docking control systems

1.6.1 950 Docking LA CD

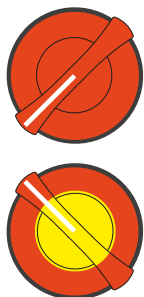
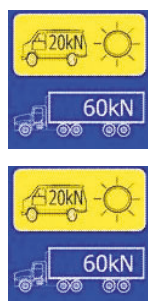

- Selector Switch for operation mode: Articulated lorries
- Selector Switch for operation mode: Small vans
- 20kN Light illuminates when weight compensation is activated.

1.6.2 950 Docking LA CD



- Hold-to-run button to lift platform.
- Hold-to-run button to position the lip on the truck bed.
- Impulse auto button to put the leveler back in parking position.
- Mains isolator or emergency stop button.
- Interface to incorporate ASSA ABLOY wheel chock.

1.6.3 950 Docking DLA CD

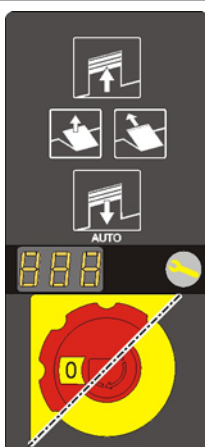

- Hold-to-run button to lift platform.
- Hold-to-run button to position the lip on the truck bed.
- Impulse auto button to put the leveler back in parking position.
- Mains isolator or emergency stop button.
- Interface to incorporate ASSA ABLOY wheel chock.
- Designed to operate an overhead sectional door in the docking station.

1.6.4 950 Docking LSA CD



- Hold-to-run button to lift platform.
- Hold-to-run button to position the lip on the truck bed.
- Impulse auto button to put the leveler back in parking position.
- Mains isolator or emergency stop button.
- Interface to incorporate ASSA ABLOY wheel chock.
- Designed to operate an inflatable shelter in the docking station.

1.6.5 950 Docking DLSA CD

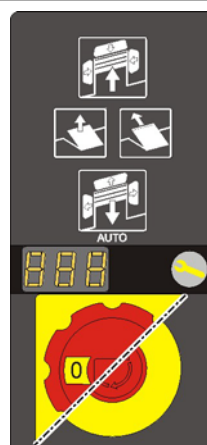

- Hold-to-run button to lift platform.
- Hold-to-run button to position the lip on the truck bed.
- Impulse auto button to put the leveler back in parking position.
- Mains isolator or emergency stop button.
- Interface to incorporate ASSA ABLOY wheel chock.
- Designed to operate an overhead sectional door and an inflatable shelter in the docking station.

1.6.6 950 Docking power cable



- Standard: 1,1 m power cable to connect to mains switch on the wall.
- Option: 1,5 m power cable with CEE-plug, pre-mounted.

1.7 Equipment

1.7.1 Buffers

Buffers placed in front of the dock leveler absorb the energy of a vehicle that accidentally or intentionally hits the building. Buffers are available in various sizes, in fixed or moving models, and with rubber finishing or steel plate and spring function.

1.7.1.1 RS

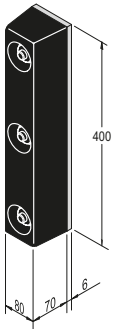

Application

The RS buffer is the economical solution for docking stations where vehicles of equal sizes load and unload. We recommend to use 2 RS buffers installed in a row on both sides of the DL6130C.

1.7.1.2 RB

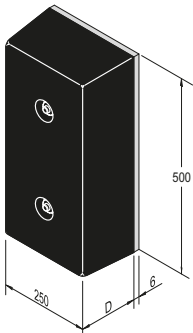

Application

The RB buffer is a large fixed rubber. It is the universal building and vehicle protection solution. Available depths:

- 90 mm
- 140 mm

1.7.1.3 RB with steel front plate

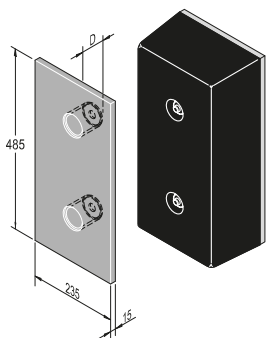

Application

The RB buffer with steel protection front plate increases the building protection and the buffer service life. Available depths:

- 90 mm
- 140 mm

1.7.1.4 RB with steel front and top plate

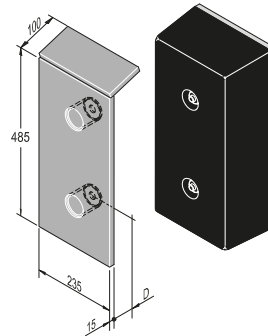

Application

The RB buffer with steel protection front and top plate is designed for vehicles with high lorry beds like interchangeable open bodies and containers.

Available depths:

- 90 mm
- 140 mm

1.7.1.5 EBH

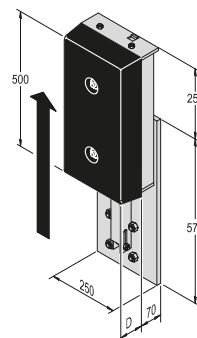

Application

The EBH buffer is the ideal solution for docking stations where vehicles of notable height differences load and unload.

This buffer can be vertically adjusted by a 'release device'.

Available depths:

- 90 mm
- 140 mm

1.7.1.6 EBF

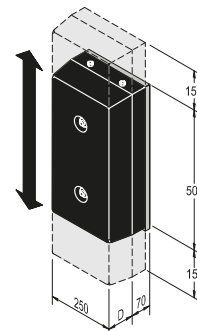

Application

The EBF buffer is the ideal solution for docking stations where vehicles are expected to make notable vertical suspension changes when loading or unloading.

This buffer follows vertical movements of the vehicle.

Available depths:

- 90 mm
- 140 mm

1.7.1.7 Steel spring buffer 800

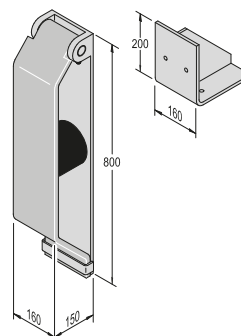

Application

The 800 mm steel spring buffer is designed for applications where vehicles generally are higher than ramp level.

1.7.1.8 Steel spring buffer 600

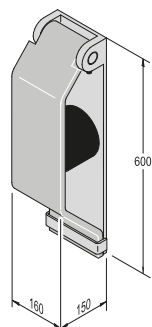

Application

The steel spring buffer is the ideal protector of the ramp as well as the vehicle itself.

1.7.5 ASSA ABLOY DE6090FL Fan light

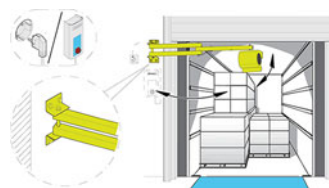

The compact fan light is a combined solution of a fan and a dock light in one system. The fan creates a continuous stream of fresh air that refreshes and cleans the air inside the trailer or container and the integrated dock light provides extensive light. It has a flexible solid arm that fits general industry and logistics applications, for an easy and fast docking process.

1.7.2 ASSA ABLOY DE6190WC Wheel chock

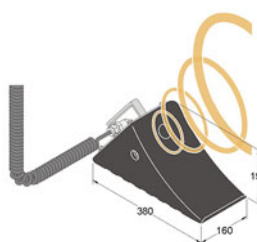

The wheel chock has a sensor to detect the presence and position of the vehicle and is connected to the dock leveler control panel. If no vehicle is detected, the docking station is blocked for safety reasons. Furthermore, the wheel chock prevents the vehicle from moving during loading/unloading.

1.7.6 Parking guides

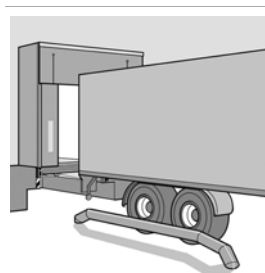

This visual aid makes it easier to park the vehicle and reduces the risk of collision. Especially advantageous for docking stations with wide leveler lips and cushion shelters. Parking guides can be bolted or cast in concrete on the floor before the leveler.

1.7.3 ASSA ABLOY DE6090TLS Traffic light system



The traffic light system either has a sensor above the dock leveler that measures the presence of the vehicle or it is a wheel chock that detects the vehicle.

If there is no vehicle (dock leveler is free), the traffic light inside is red, outside is green.

The traffic light can also be combined with a wheel chock or door/leveler interlocking.

1.7.4 ASSA ABLOY DE6090DL Dock light Heavy Duty LED

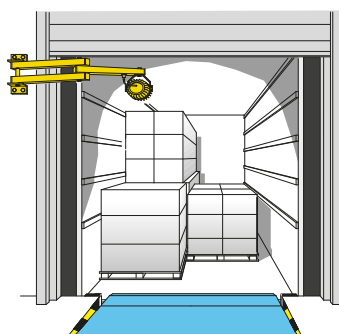

Where dock lights are often a vulnerable object in the docking area, the virtually indestructible Dock Light Heavy Duty LED is the perfect solution to bring light in the truck and docking area. It is designed for the most demanding environments and can withstand possible hard hits from a moving forklift without being damaged.

2. Selection guide

2.1 Load capacity according to EN 1398

The EN 1398 describes 3 key definitions about loads.

2.1.1 Rated load

The rated load is the total weight of the goods, the forklift truck and the driver.



2.1.2 Axle load

Axle loads shall be taken acting over two rectangular contact areas at 1 m lateral distance. These areas shall only apply if the actual conditions do not call for more severe loading. The size of the footprint [mm²] is derived from the wheel load [N] divided by 2 [N/mm²]. The ratio of the rectangular print is W:L = 3:2.

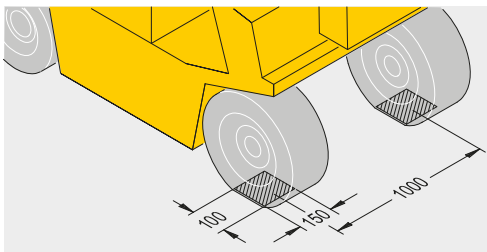

In the drawing measures for a leveler with a load capacity of 100kN or 150kN are shown.

2.1.3 Dynamic load

The dynamic load is the movement of the rated load and is the pressure on the leveler platform caused by the moving forklift truck.

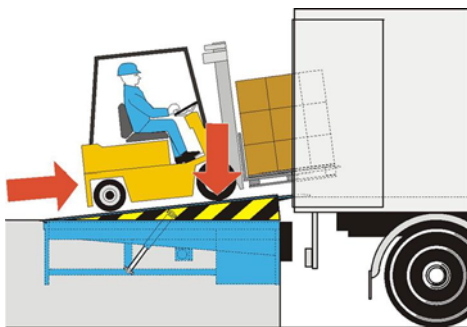

2.2 Select the load capacity

The load capacity of a dock leveler must always be higher than the rated load.

2.2.1 Example for lorries

Weight of forklift truck	3600 kg
Weight of goods	1500 kg
Weight of driver	100 kg
Total weight/rated load	5200 kg
Suitable load capacity of the leveler	6000 kg/60kN

2.2.2 Example for vans

Weight of pallet truck	100 kg
Weight of goods	1500 kg
Weight of driver	100 kg
Total weight/rated load	1700 kg
Suitable load capacity of the leveler	2000 kg/20kN

2.3 Select the leveler length

When determining the leveler length, measure the maximum height difference between the truck bed and the dock level. Next, determine which vehicles will be used and lookup the maximum gradient the vehicles are allowed to be used on.

Vehicle	Max gradient
Roll cage	3%
Hand pallet truck	3%
Electric pallet truck	7%
Forklift truck (battery)	10%
Forklift truck (gas / petrol)	15%

2.3.1 The calculation

Minimal leveler length = height difference / gradient (%)

2.3.2 Example

Vehicle:	Electric pallet truck (max 7% gradient)
Truck height:	1350 – 1000 mm
Dock height:	1150 mm

The difference between Truck height and Dock height = 175 mm

175 mm / 7% = 2500 mm leveler length

2.4 Nominal width

The correct nominal width must exceed the widest loading vehicle by at least 700 mm. The ASSA ABLOY DL6130C combidock is available with a nominal width of 2000, 2200 mm.

3. Specifications

3.1 Dimensions



Abb.	Dimension
NL	Nominal length
OL	Overall length (NL +500 mm)
GL	Gradient length (NL + 360 mm)
NW	Nominal width (= 2000, 2200 mm)
LE	Leveler extension
LH	Leveler height
A	Working range above dock level
B	Working range below dock level
PD	Pit depth
LP	Lowest Position
TL	Tail lift area
3	Leveler frame

Dimensions 500 mm lip

Vertical Working range 60kN mode**

NL	LH	LP	A	B - inside LH*	B - down to LP	DH
3000	800	950	450	375	550	1200
3500	900	1150	560	275	650	1200
4000	900	1150	560	270	650	1200
4500	900	1165	560	260	650	1200

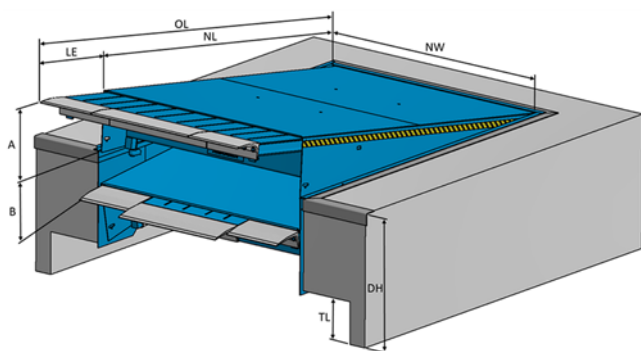
Vertical Working range 20kN mode**

NL	LH	LP	A	B - inside LH*	B - down to LP	DH
3000	800	950	100	375	550	1200
3500	900	1135	100	275	650	1200
4000	900	1150	100	270	650	1200
4500	900	1165	100	260	650	1200

Dimensions 1000 mm lip

Vertical Working range 60kN mode**

NL	LH	LP	A	B - inside LH*	B - down to LP	DH
3000	800	950	540	420	620	1200
3500	900	1135	620	300	700	1200
4000	900	1150	620	290	700	1200
4500	900	1165	620	280	700	1200

Vertical Working range 20kN mode**

NL	LH	LP	A	B - inside LH*	B - down to LP	DH
3000	800	930	100	420	620	1200
3500	900	1135	100	300	700	1200
4000	900	1150	100	290	700	1200
4500	900	1165	100	280	700	1200

* When tail lift is in use

** In accordance with the EN 1398 standard, the leveler must not be used beyond the permissible gradient range of $\pm 12.5\%$ (around $\pm 7^\circ$). The limits may only be exceeded if the operator ensures that the danger of slipping has been eliminated (e.g. due to dry and clean surfaces).

3.1.1 Working range below dock B* – inside LH

The effectively usable working range below dock (B) is down to the point inside LH (B*), when the vehicles have a tail lift like some conventional articulated lorries.

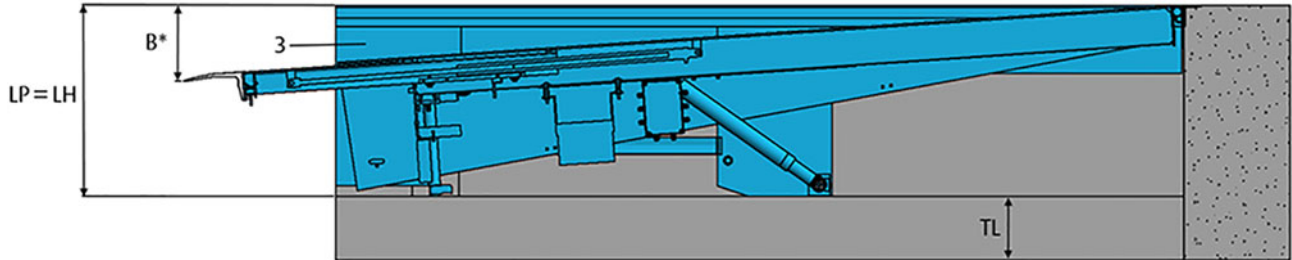

3.1.2 Working range below dock B – down to LP

The effectively usable working range below dock (B) is down to lowest point (LP), when the vehicles do not have a tail lift like most conventional small vans.

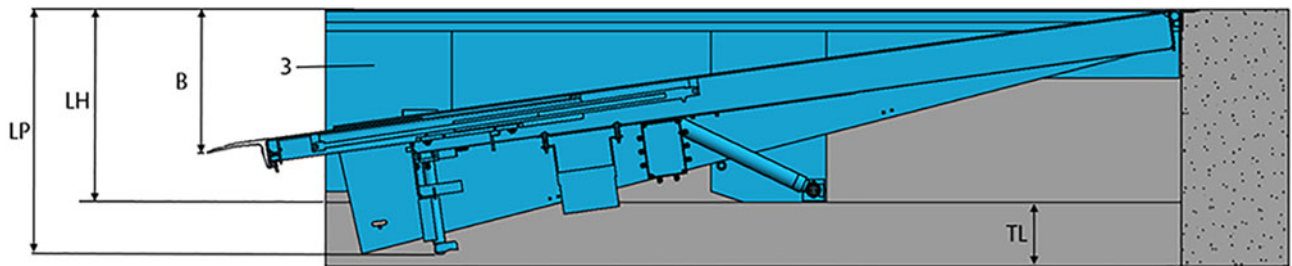

3.2 Platform thickness

Thickness	Max. point load
8 mm (8/10)	6,5 N/mm ²



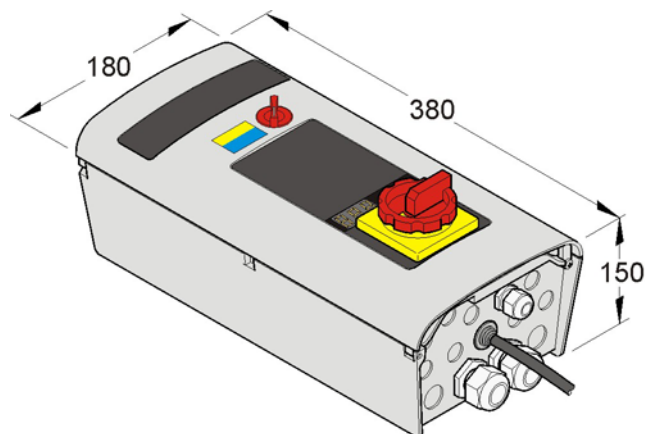

3.3 Control unit

3.3.1 Dimensions



950 series

3.3.2 Functions

Functions included	LA-CD	DLA-CD	LSA-CD	DLSA-CD
				
Hold to run button	<input checked="" type="checkbox"/>	<input checked="" type="checkbox"/>	<input checked="" type="checkbox"/>	<input checked="" type="checkbox"/>
Close (hold to run)	<input checked="" type="checkbox"/>	<input checked="" type="checkbox"/>	<input checked="" type="checkbox"/>	<input checked="" type="checkbox"/>
Impulse auto button	<input checked="" type="checkbox"/>	<input checked="" type="checkbox"/>	<input checked="" type="checkbox"/>	<input checked="" type="checkbox"/>
Extend lip (hold to run)	<input checked="" type="checkbox"/>	<input checked="" type="checkbox"/>	<input checked="" type="checkbox"/>	<input checked="" type="checkbox"/>
Mains isolator	<input checked="" type="checkbox"/>	<input checked="" type="checkbox"/>	<input checked="" type="checkbox"/>	<input checked="" type="checkbox"/>
Emergency stop button	<input type="checkbox"/>	<input type="checkbox"/>	<input type="checkbox"/>	<input type="checkbox"/>
400V	<input checked="" type="checkbox"/>	<input checked="" type="checkbox"/>	<input checked="" type="checkbox"/>	<input checked="" type="checkbox"/>
230V	<input type="checkbox"/>	<input type="checkbox"/>	<input type="checkbox"/>	<input type="checkbox"/>
Maintenance indicator	<input checked="" type="checkbox"/>	<input checked="" type="checkbox"/>	<input checked="" type="checkbox"/>	<input checked="" type="checkbox"/>
3 Digit display	<input checked="" type="checkbox"/>	<input checked="" type="checkbox"/>	<input checked="" type="checkbox"/>	<input checked="" type="checkbox"/>
Memory function	<input checked="" type="checkbox"/>	<input checked="" type="checkbox"/>	<input checked="" type="checkbox"/>	<input checked="" type="checkbox"/>
BUS network interface	<input type="checkbox"/>	<input type="checkbox"/>	<input type="checkbox"/>	<input type="checkbox"/>
Wheel chock	<input type="checkbox"/>	<input type="checkbox"/>	<input type="checkbox"/>	<input type="checkbox"/>
Door control		<input checked="" type="checkbox"/>		<input checked="" type="checkbox"/>
Shelter control			<input checked="" type="checkbox"/>	<input checked="" type="checkbox"/>

Standard

Option / Available

4. CEN Performance

4.1 Safety according to the European Standard EN 1398

- Emergency Stop Function.
 - Safety valves block lowering movement after max. 6% of the nominal length of the leveler.
 - Two lift cylinders make sure the leveler stops in a horizontal position.
- Free floating position.
- Platform torsion. Lateral deflection of at least 3% of nominal width.
- Toe guards cover gap between platform and pit in leveler's highest position.
- Working range gradient max. 12,5% (~7°).
- Warning stripes on side plates and on frame (black/yellow).

5. Building and space requirements

5.1 Electrical preparations

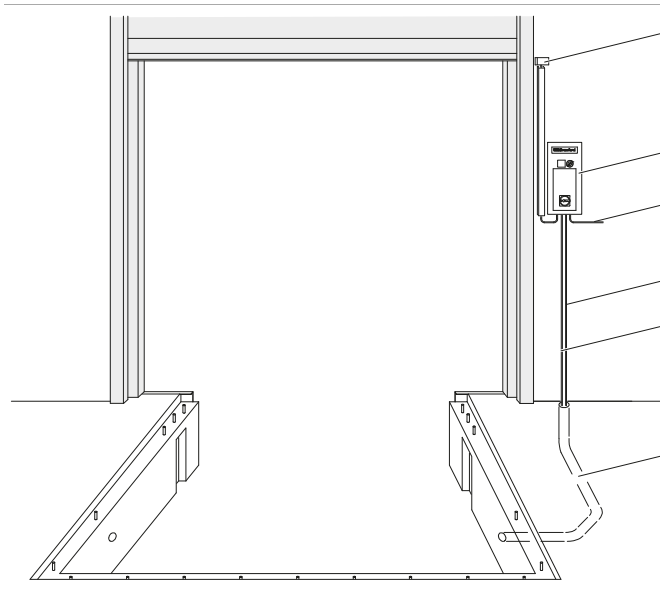

- 1 Control unit (included in the delivery)
- 2 Conduit for wiring internal diameter 50, angles <math><45^\circ</math> (by others)
- 3 Mains supply: 3/N/PE AC 50 Hz
Mains fuse: 400V 3-phase, 230V 3-phase
Motor power: D0 10 A gL
1,5 kW
- 4 Control cable: 18 x 0,75 mm²
- 5 Main connection 230V: 4 x 1,5 mm²
- 6 Optional safety switch on sectional door to disable leveler when door is closed*

*Non standard

5.2 Pit preparations

This section illustrates the required pit preparations for each frame type for the ASSA ABLOY DL6130C combidock.

5.2.1 T - frame (T standard and T200)

With tail lift recess

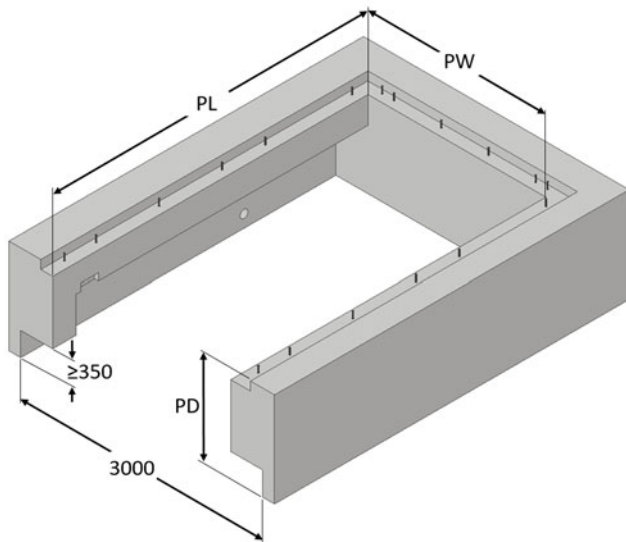

Pit drawing 5143.0275

Without tail lift recess

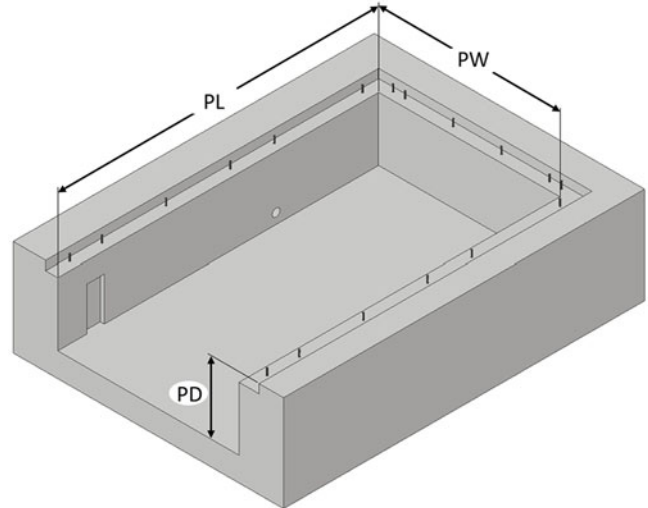

Pit drawing 5143.0276

5.2.2 W - frame

With tail lift recess

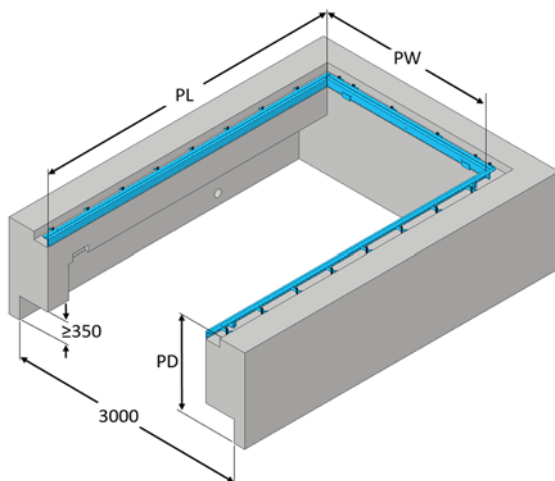

Pit drawing 5143.0277

Without tail lift recess

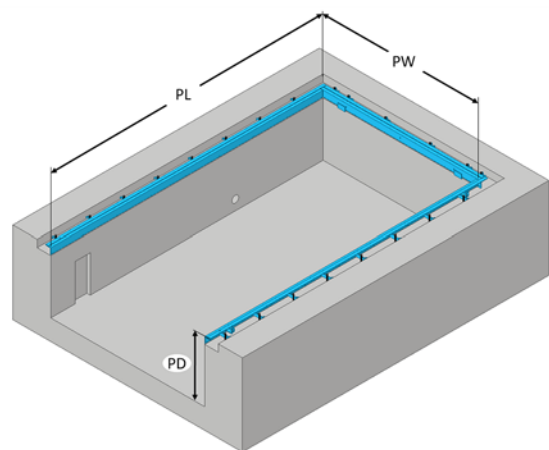

Pit drawing 5143.0278

6. Service you can rely on



Gold

The ultimate protection

With full coverage, Gold Service enables you to plan and budget your expenses annually.

- Spare parts for emergency calls
- Labor and travel costs for emergency calls
- Replacement of components according to preventive maintenance schedule and to fulfill legislative and safety requirements

Silver

Added advantages

With cover for all service calls during business hours, Silver Service offers you peace of mind.

- Labor and travel costs for emergency calls
- Preventive maintenance

Bronze

Scheduled Service

With scheduled on site visits, Bronze Service means you know that your doors and docking systems will be regularly serviced and inspected.

- Preventive maintenance

Included in all packages

1-4 scheduled maintenance visits per year

24/7 priority service hotline and fast response

Safety, compliance and quality control checks

Documentation reports provided on site

Expert service you can rely on

A healthy business enjoys a steady flow of goods, services and people through its entrances every day. But heavy traffic puts entrances under pressure as every component works to keep them running.

ASSA ABLOY Entrance Systems offer the industry's most complete, flexible service solutions. Because even something as robust and well-engineered as an ASSA ABLOY door or docking system needs to be serviced to stay in great working order.

Pro-active care packages

An ASSA ABLOY service agreement gives you service you can rely on. We have specialized local service technicians on call to take care of your service needs. Equipped with a wide range of spare parts and expertise, to keep your industrial doors and docking systems running.

With an ASSA ABLOY service agreement you can ensure reliable, safe and sustainable operations at every entrance under your agreement, including doors and docking systems, independent of brand.

ASSA ABLOY e-maintenance™ (optional add-on)

For an online overview of your entrance systems and history, add ASSA ABLOY e-maintenance™ to your service package for:

- Easy access to real-time data on all your doors
- Planning, order and service information
- Overview that helps you control lifecycle costs

Index

Numerics

950 Docking DLA CD	11
950 Docking DLSA CD	11
950 Docking LA CD	11
950 Docking LSA CD	11
950 Docking power cable	11

A

Application	6
ASSA ABLOY DE6090DL Dock light Heavy Duty LED	13
ASSA ABLOY DE6090FL Fan light	13
ASSA ABLOY DE6090TLS Traffic light system	13
ASSA ABLOY DE6190WC Wheel chock 13	
Axle load	14

B

Big truck	7
Buffers	12
Building and space requirements	20

C

CEN Performance	19
City van	7
Colors	9
Control unit	18
Copyright and Disclaimer Notice	2

D

Description	6
Dimensions	16, 18
Docking control systems	11
Dynamic load	14

E

EBF	12
EBH	12
Electrical preparations	20
EPDM seal	8
Equipment	12
Example	14
Example for lorries	14
Example for vans	14

F

Features	3
Frames - connection to building	10
Function telescopic lip in city van mode 8	
Functions	18

G

General	6
---------------	---

H

Hot galvanising	9
-----------------------	---

L

Load capacity according to EN 1398 14	
---	--

M

Mini-combidock lip	7
Mode of operation	6

N

Nominal width	15
---------------------	----

O

Options	6
Overview	6

P

Paint classes	9
Painting	9
Parking guides	13
Performance	3
Pit preparations	21
Platform	8
Platform tear-plate thickness	8
Platform thickness	18

R

Rated load	14
RB	12
RB with steel front and top plate	12
RB with steel front plate	12
RS	12

S

Safety according to the European Standard EN 1398	19
Select the leveler length	14
Select the load capacity	14
Selection guide	14
Service you can rely on	22
Slip protection / noise reduction	8
Specifications	16
Standard	6
Standard paint class	9
Steel spring buffer 600	13
Steel spring buffer 800	12
Surface	9

T

T - 200 leveler frame for embedding in concrete	10
T - frame (T standard and T200)	21
T - leveler frame for embedding in concrete	10
Technical facts	3
The calculation	14

W

W - frame	21
W - leveler frame for welding	10
Working range below dock B – down to LP	17
Working range below dock B* – inside LH	17

The ASSA ABLOY Group is the global leader in access solutions.
Every day, we help billions of people to experience a more open world.

ASSA ABLOY
Entrance Systems

ASSA ABLOY Entrance Systems provides solutions for efficient and safe flow of goods and people. Our offering includes a wide range of automated pedestrian, industrial and residential doors, loading dock equipment, perimeter fencing and service.