

Swing Gate

ASSA ABLOY GS100 Series

ASSA ABLOY
Entrance Systems

Experience a safer
and more open world



Redirect your people flow with a well-designed, multi-option swing gate – so your building’s private areas can always fulfil their function.

The swing gate GS100 from ASSA ABLOY is a compact yet sturdy access point solution that helps divert unwanted traffic from non-public areas of your building. Its stainless steel post and swivel arm, together with the customizable, acrylic inner plate, have been proven to stand heavy use, and its swing door mechanism is consistently easy to use by hand.

Emergency and power outage modes*

In the event of an emergency, the gate unlocks and the barrier wing can swing freely. Once the emergency alarm stops and/or the electricity returns, the gate locks itself automatically.

* Valid only for the WE 1 and WE 2 models, with electric locks.

Accessories

- Remote control unit
- Stainless steel post for opposing side
- Company logo on barrier wing
- Posts for access control unit

Design specification

Construction	Stainless steel
Passage width	max. 1000 mm
Barrier wing length	max. 900 mm
Post height	1014 mm
Post diameter	102 mm
Weight	18 kg
Opening and closing times	1.5 sec

Options

WS 1	One-way (without lock)
WS 2	Two-way (without lock)
WL 1	One-way (with mechanical lock)
WL 2	Two-way (with mechanical lock)
WE 1	One-way (with electric lock)
WE 2	Two-way (with electric lock)

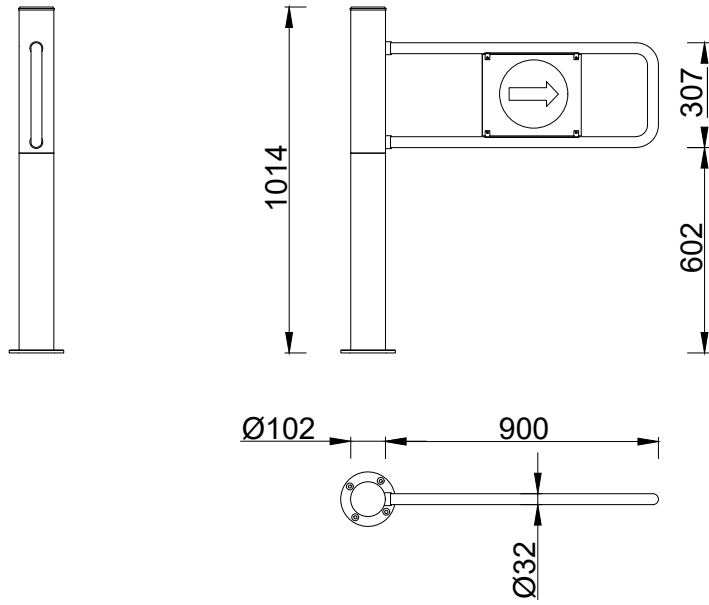

This equipment should be installed, regularly inspected, maintained and serviced by trained and authorized personnel. Preventive maintenance plans are highly recommended for a proper and safe operation. Talk to your ASSA ABLOY Entrance Systems representative to learn more about our service offering!